

An Autonomous Institute
Affiliated to VTU, Belagavi,
Approved by AICTE, New Delhi,

DEPARTMENT OF MEDICAL ELECTRONICS ENGINEERING

SUBJECT CODE : 18ML42

SUBJECT NAME: COMMUNICATION SYSTEMS

LECTURE PRESENTATION

FACULTY : Dr. D. K. RAVISH, Assoc. Prof, Dept. of ML

.



Introduction

Elements of Communication System:

Communication: It is the process of conveying or transferring information from one point to another.

(Or)

It is the process of establishing connection or link between two points for information exchange.

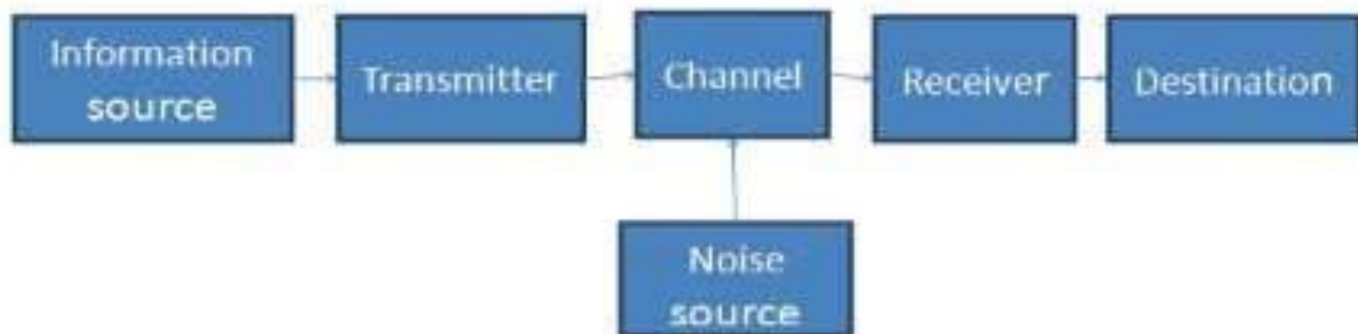

Elements of Communication System:

Information source:

The message or information to be communicated originates in information source.

Message can be words, group of words, code, data, symbols, signals etc.

Transmitter :

The objective of the transmitter block is to collect the incoming message signal and modify it in a suitable fashion (if needed), such that, it can be transmitted via the chosen channel to the receiving point.

Elements of Communication System:

Channel :

Channel is the physical medium which connects the transmitter with that of the receiver.

The physical medium includes copper wire, coaxial cable, fibre optic cable, wave guide and free space or atmosphere.

Receiver:

The receiver block receives the incoming modified version of the message signal from the channel and processes it to recreate the original (non-electrical) form of the message signal.

Signal, Message, Information

Signal:

It is a physical quantity which varies with respect to time or space or independent or dependent variable.

(Or)

It is electrical waveform which carries information.

$$\text{Ex: } m(t) = A \cos(\omega t + \varphi)$$

Where, A = Amplitude or peak amplitude (Volts)

ω = Frequency (rad/sec)

φ = Phase (rad)

Types of Signals

- Analog or Continuous Signal
- Digital Signal

Analog or Continuous Signal: If the amplitude of signal continuously varies with respect to time or if the signal contains infinite number of amplitudes, it is called Analog or continuous signal.

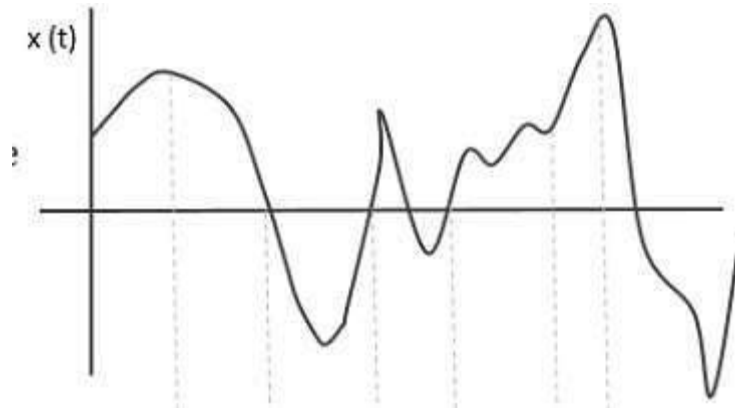

Types of Signals

Digital Signal: If the signal contains only two discrete amplitudes, then it is called digital signal.

- With respect to communication, signals are classified into,
- Baseband signal
- Bandpass signal

Baseband signal: If the signal contains zero frequency or near to zero frequency, it is called baseband signal.

Ex: Voice, Audio, Video, Bio-medical signals etc.

Types of Signals

Bandpass signal: If the signal contains band of frequencies far away from base or zero, it is called bandpass signal.

Ex: AM, FM signals.

Message: It is sequence of symbols.

Ex: Happy New Year 2020.

Information: The content in the message is called information. It is inversely proportional to probability of occurrence of the symbol.

- Information is measured in bits, decits, nats.

Limitations of Communication System

- **Technological Problems:**

To implement communication systems, Tx, Rx, channel are required which requires hardware. Communication system is expensive and complex.

- **Bandwidth & Noise:**

The effect of noise can be reduced by providing more bandwidth to stations but due to this less number of stations can only be accommodated.

- **Signal to Noise Ratio (SNR):**Noise should be low to increase channel capacity but it is an unavoidable aspect of communication system.

Modulation

It is the process of varying the characteristics of high frequency carrier in accordance with instantaneous values of modulating or message or baseband signal.

(Or)

It is a frequency translation technique which converts baseband or low frequency signal to bandpass or high frequency signal.

Modulation is used in the transmitter.

Types of Modulation

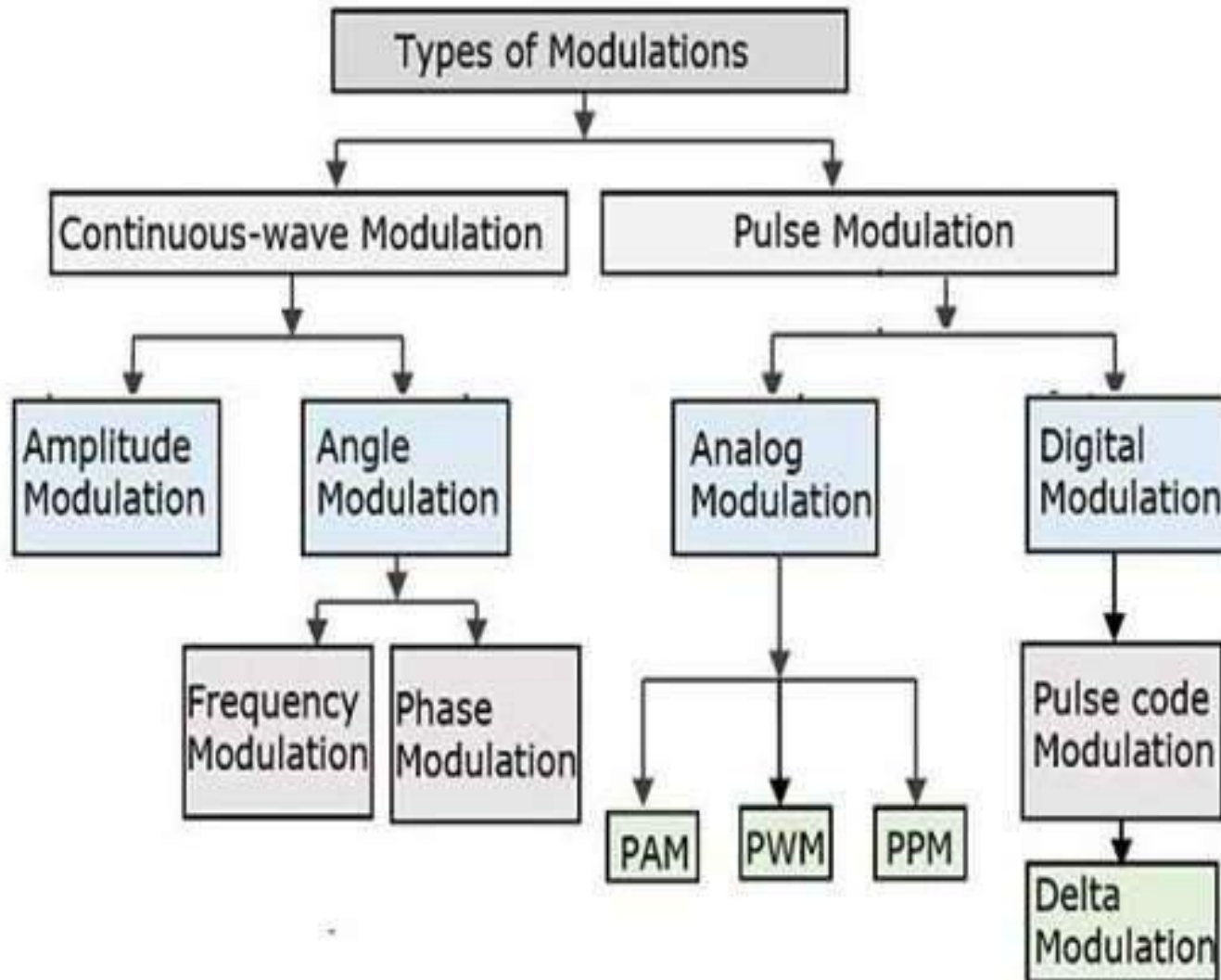

Types of Modulation

- **Amplitude Modulation:** Amplitude of the carrier is varied in accordance with the instantaneous values of modulating signal.
- **Frequency Modulation:** Frequency of the carrier is varied in accordance with the instantaneous values of modulating signal.
- **Phase Modulation:** Phase of the carrier is varied in accordance with the instantaneous values of modulating signal.

Benefits or Need of Modulation

- To reduce the length or height of antenna
- For multiplexing
- For narrow banding or to use antenna with single or same length
- To reduce noise effect
- To avoid equipment limitation or to reduce the size of the equipment.

The amplitude of the carrier signal varies in accordance with the instantaneous amplitude of the modulating signal.

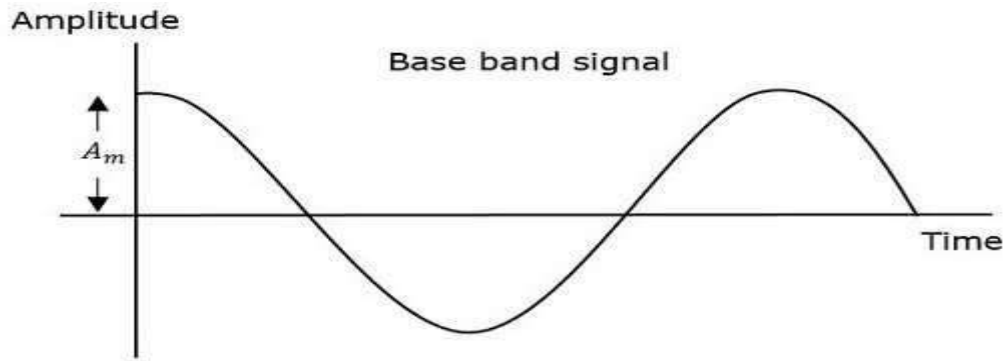

n

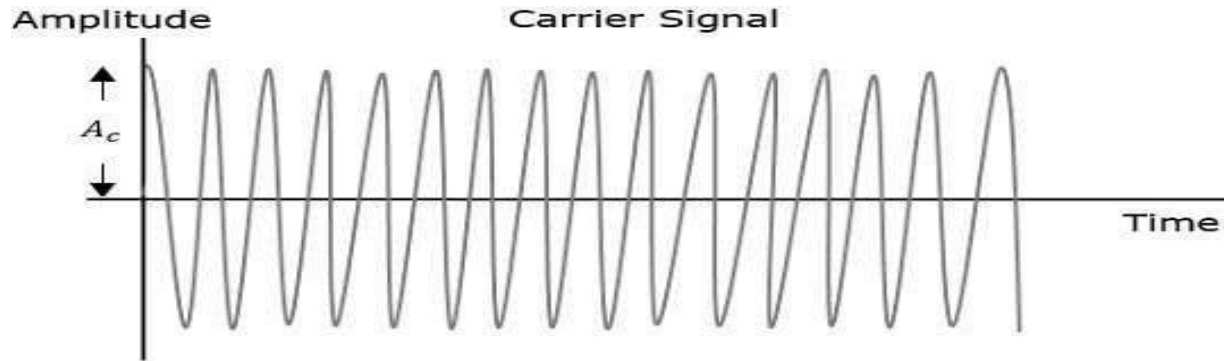

Amplitude Modulation

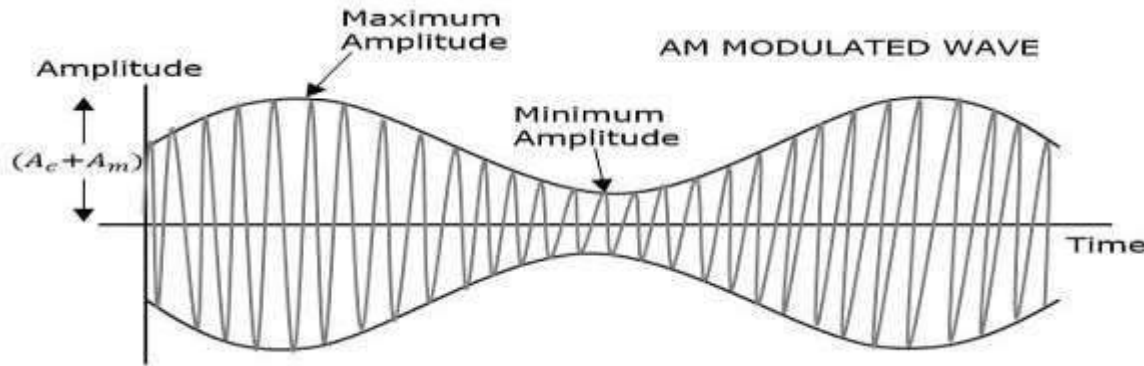

The carrier signal is given by,

$$C(t) = A_c \cos w_c t$$

Where, A_c = Maximum amplitude of the carrier signal.

$W = 2\pi f_c$ = Frequency of the carrier signal.

Modulating or baseband signal is given by,

$$X(t) = A_m \cos w_m t$$

Where, A_m = Amplitude of the baseband signal.

Amplitude Modulation

The standard equation for amplitude modulated signal is expressed as,

$$S(t) = A_c \cos 2\pi f_c t [1 + m_a (\cos 2\pi f_m t)]$$

Where, $m_a = A_m/A_c = \text{Modulation Index}$

Time Domain representation of AM:

$$S(t) = A_c \cos 2\pi f_c t + \mu A_c / 2 \cos [2\pi f_c + 2\pi f_m] t + \mu A_c / 2 \cos [2\pi f_c - 2\pi f_m] t$$

I term: Carrier signal with amplitude A_c and frequency f_c .

II. term: Amplitude = $\mu A_c / 2$, frequency = $f_c + f_m$, Upper sideband frequency

III. term: Amplitude = $\mu A_c / 2$, frequency = $f_c - f_m$, Lower sideband frequency

Amplitude Modulation

Frequency Domain representation of AM:

The time domain representation of AM wave is given by,

$$S(t) = A_c \cos 2\pi f_c t [1 + m_a (\cos 2\pi f_m t)]$$

Taking Fourier transform on both sides,

$$S(f) = A_c/2 [\delta(f-f_c) + \delta(f+f_c)] + A_c m_a/2 [M(f-f_c) + M(f+f_c)]$$

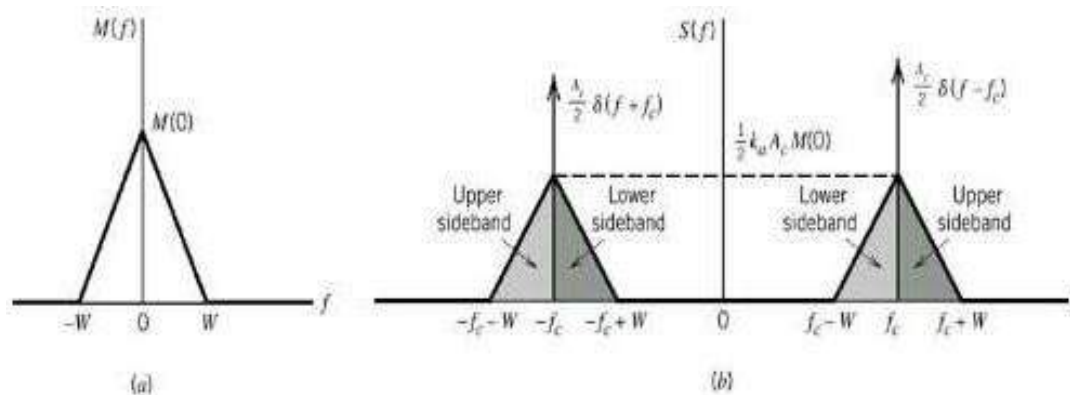

Modulation Index

Modulation index or depth of modulation is given by,

$$m_a = [A_{\max} - A_{\min} / A_{\max} + A_{\min}] = A_m / A_c$$

Percentage of modulation index is,

$$\%m_a = [A_{\max} - A_{\min} / A_{\max} + A_{\min}] \times 100 = [A_m / A_c] \times 100$$

Types of AM with respect to modulation index:

- Under Modulation ($m_a < 1$)
- Critical Modulation ($m_a = 1$)
- Over Modulation ($m_a > 1$)

Types of AM

Under modulation :- $m_a < 1 \Rightarrow \frac{A_m}{A_c} < 1$ (or) $A_m < A_c$

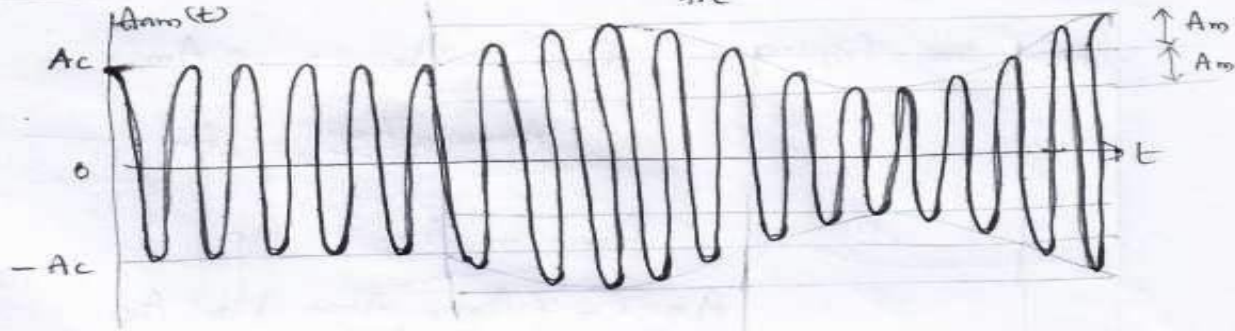

Critical Modulation :- $m_a = 1 \Rightarrow \frac{A_m}{A_c} = 1$ (or) $A_m = A_c$



Over modulation $m_a > 1 \Rightarrow m_a \geq \frac{A_m}{A_c} > 1$

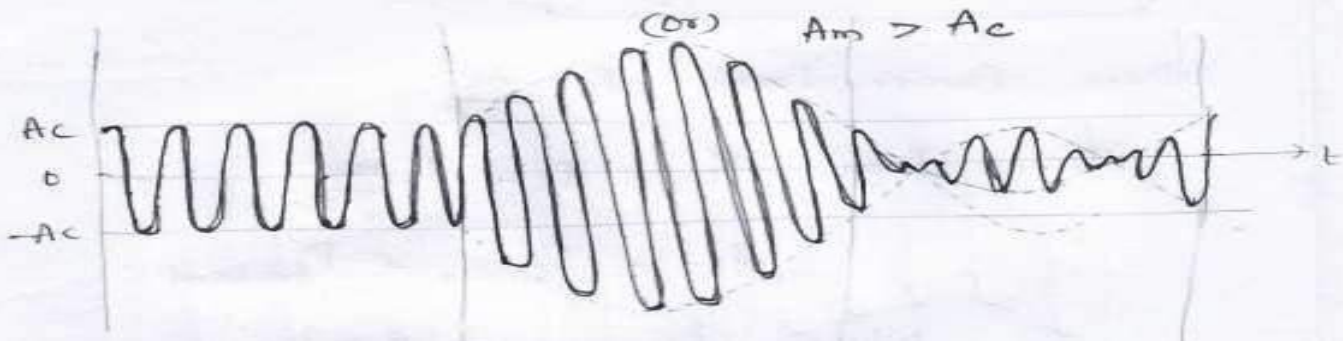

Generation of AM Wave

Square Law modulator:

This circuit consists of,

- A non-linear device
- Band pass filter
- Carrier source and modulating signal

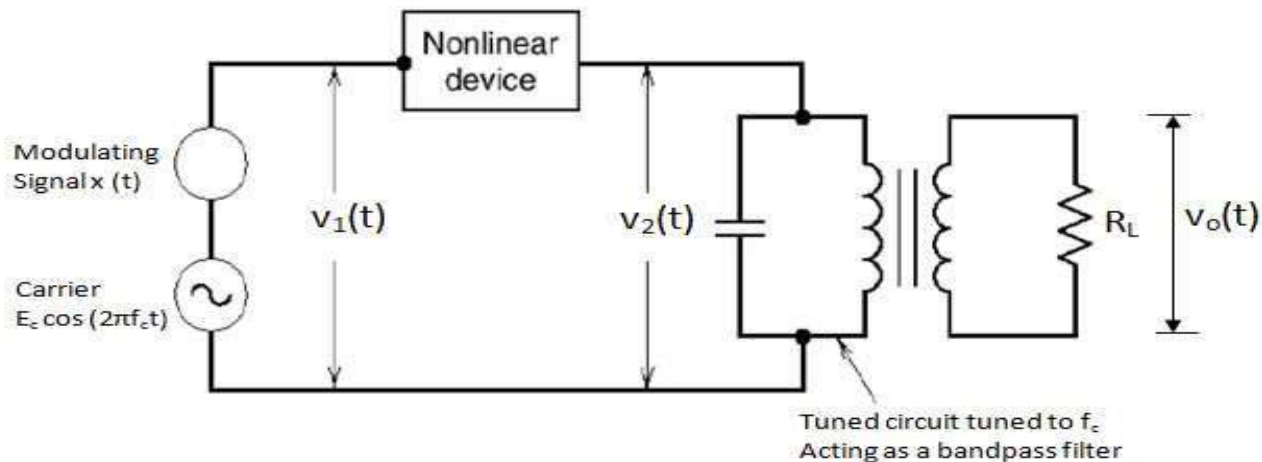

Generation of AM Wave

The modulating signal and carrier are connected in series with each other and their sum $V_1(t)$ is applied at the input of non-linear device such as diode or transistor.

$$V_1(t) = x(t) + A_c \cos Wct \text{ --- (1)}$$

The input-output relation of non-linear device is,

$$V_2(t) = aV_1(t) + b V_1^2(t) \text{ --- (2)}$$

Using (1) in (2),

$$V_2(t) = a x(t) + a A_c \cos (2\pi fct) + bx^2(t) + 2bx(t) A_c \cos (2\pi fct) + b A_c^2 \cos^2 (2\pi fct) \text{ --- (3)}$$

Out of these 5 terms, 1,3,5 terms are unuseful terms are eliminated by BPF.

Generation of AM Wave

Output of BPF is given by,

$$V_0(t) = a A_c \cos(2\pi f_c t) + 2bx(t) A_c \cos(2\pi f_c t) \text{---(4)}$$

Switching Modulator:

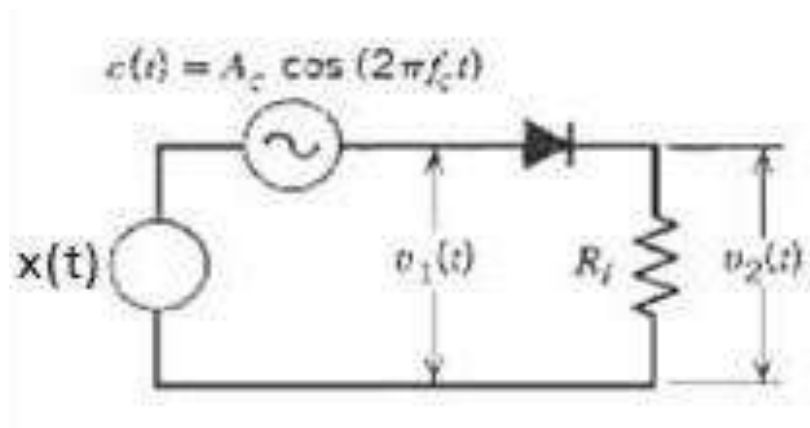

Generation of AM Wave

The carrier signal $c(t)$ is connected in series with modulating signal $x(t)$.

Sum of these two signals is passed through a diode.

Output of the diode is passed through a band pass filter and the result is an AM wave.

$$V_1(t) = x(t) + c(t) \text{ ---(1)}$$

Amplitude of $c(t)$ is much greater than $x(t)$, so ON & OFF of diode is determined by $c(t)$

When $c(t)$ is positive, $V_2(t) = V_1(t) \text{ ---(2)}$

When $c(t)$ is negative, $V_2(t) = 0 \text{ ---(3)}$, Finally,

$$V_2(t) = \frac{m(t)}{2} + \frac{A_c}{2} \cos Wct + \frac{2}{\pi} x(t) \cos wct + \frac{2}{\pi} A_c \cos^2 wct$$

Detection of AM Wave

Demodulation or detection is the process of recovering the original message signal from the received modulated signal.

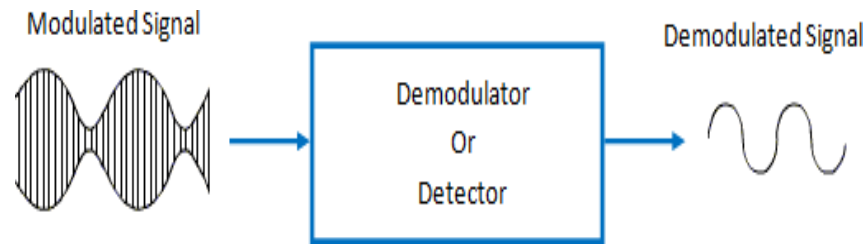

Types of AM Detectors:

1. Square Law detector
2. Envelope detector
3. Rectifier detector

Detection of AM Wave

Square Law detector:

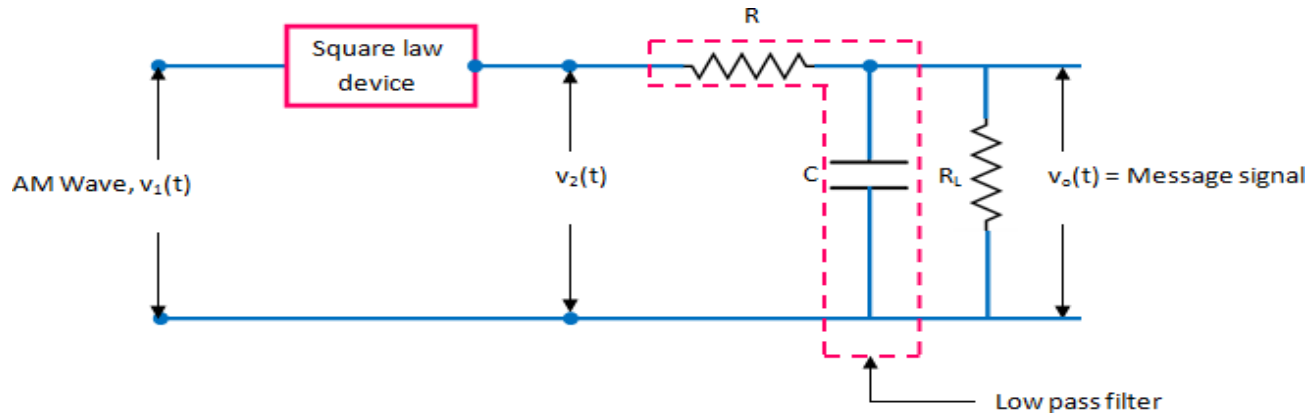

The amplitude modulated wave is given as input to the square law device.

$$V_2(t) = aV_1(t) + bV_1^2(t) \text{---(1)}$$

When this is passed through square law device,

$$V_2(t) = aA_c \cos wct + aA_c m_x(t) \cos wct + bA_c^2 \cos^2 wct + 2bA_c^2 m_x(t) \cos^2 wct + bA_c^2 m^2 x^2(t) \cos^2 wct \text{---(2)}$$

Detection of AM Wave

In order to extract the original message signal, $V_2(t)$ is passed through a low pass filter .

The output of LPF is,

$$V_0(t) = mbAc^2x(t) \text{ ---(3)}$$

Envelope Detector:

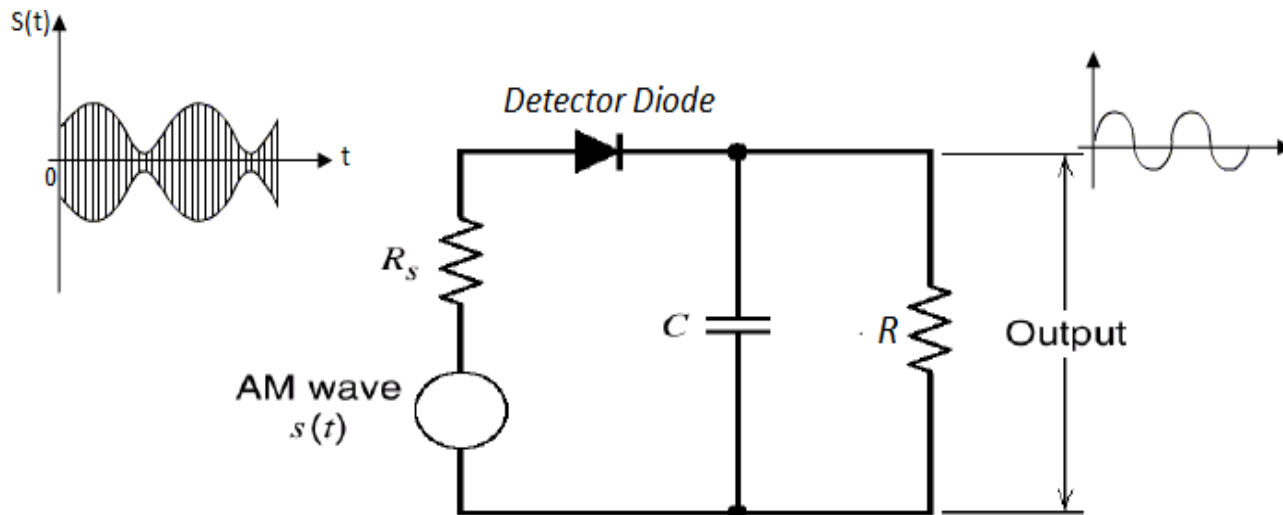

Detection of AM Wave

- The standard AM wave is applied at the input of detector .
- In every positive half cycle of input, diode is forward biased which charges capacitor 'C'.
- When capacitor charges to peak value of input voltage, diode stops conducting.
- The capacitor discharges through 'R' between positive peaks.
- This process continuous and capacitor charges and discharges repeatedly.

Detection of AM Wave

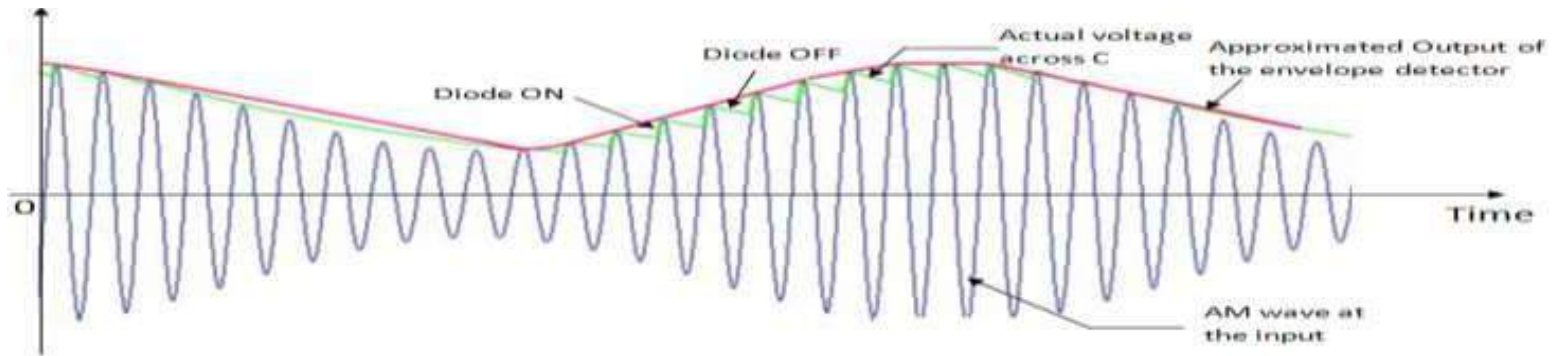

Rectifier detector:

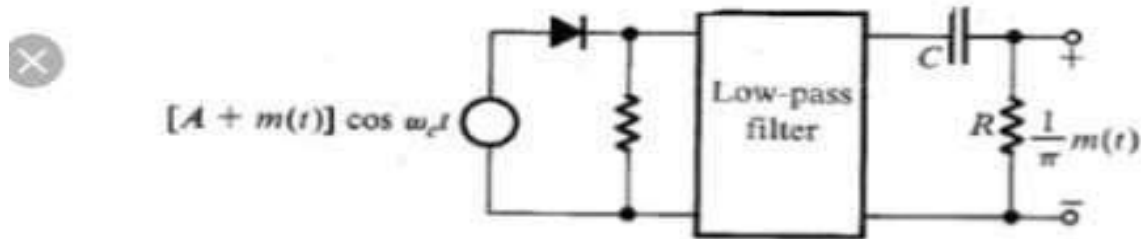

The rectified output V_R

$$\begin{aligned}
 v_r &= \left\{ [A + m(t) \cos \omega_c t] \right\} w(t) \\
 &= [A + m(t)] \cos \omega_c t \left[\frac{1}{2} + \frac{2}{\pi} \left(\cos \omega_c t - \frac{1}{3} \cos 3\omega_c t + \frac{1}{5} \cos 5\omega_c t - \dots \right) \right] \\
 &= \frac{1}{\pi} [A + m(t)] + \text{other Terms}
 \end{aligned}$$

Detection of AM Wave

- In rectifier detector, diode acts as rectifier which allows only positive half of the modulated signal to the filter.
- The low pass filter removes all the high frequency components giving envelope at its output.
- This envelope will have some dc value which can be removed by passing through capacitor 'C'.
- The output of rectifier detector is the envelope with zero dc value.

Double Sideband-Suppressed

Carrier(DSB-SC)

The equation of AM wave in simple form is given by,

$$S(t) = A_c \cos w_c t + \frac{A_c}{2} \cos(w_c + w_m)t + \frac{A_c}{2} \cos(w_c - w_m)t$$

Here, carrier component remains constant and does not convey any information.

Therefore, if the carrier is suppressed, only sidebands remain in the spectrum requiring less power.

- DSB-SC Contains two side bands i.e USB & LSB
- Power efficiency is 100%
- % Power saving in DSB-SC w.r.t AM is 66.67%.

DSB-SC Modulation

A DSB-SC signal is obtained by multiplying the modulating signal $x(t)$ with carrier signal $c(t)$.

So, we need a product modulator for the generation of DSB-SC wave.

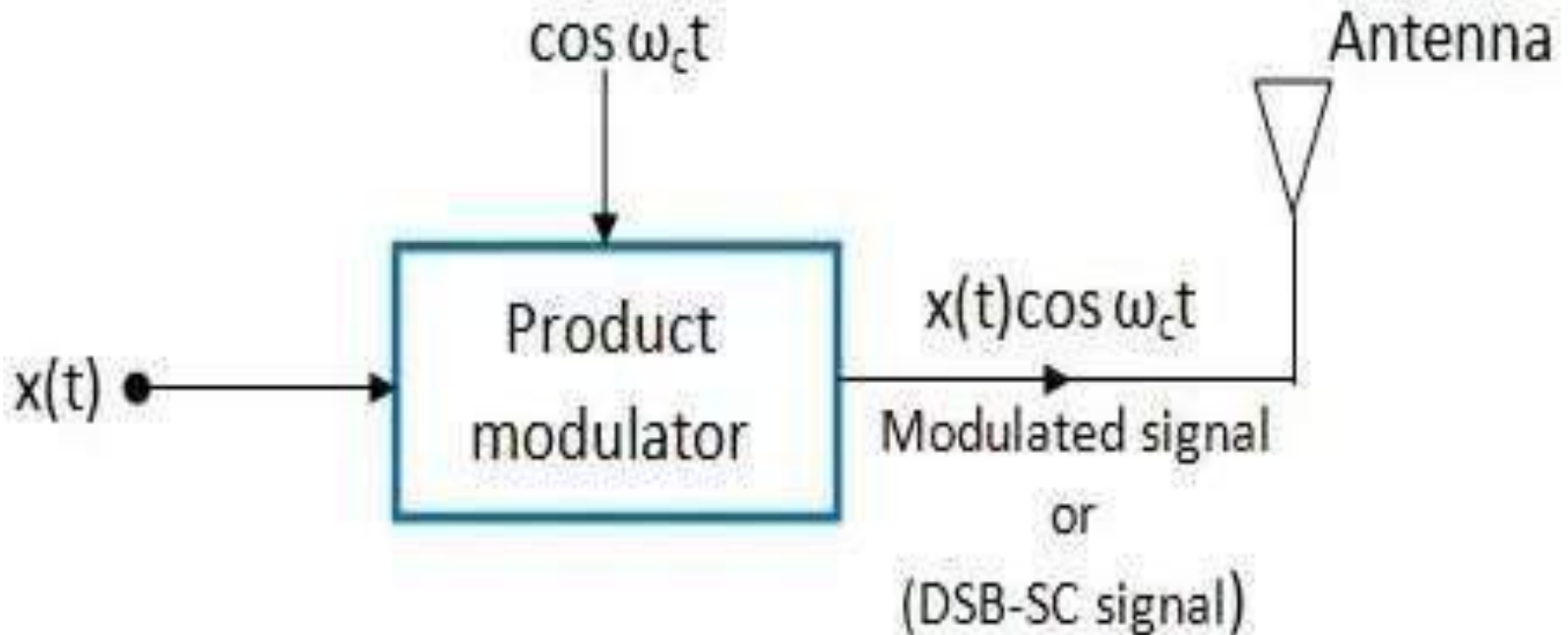

DSB-SC Modulation

1. Balanced Modulator:

It consists of two amplitude modulators arranged in balanced configuration to suppress the carrier completely.

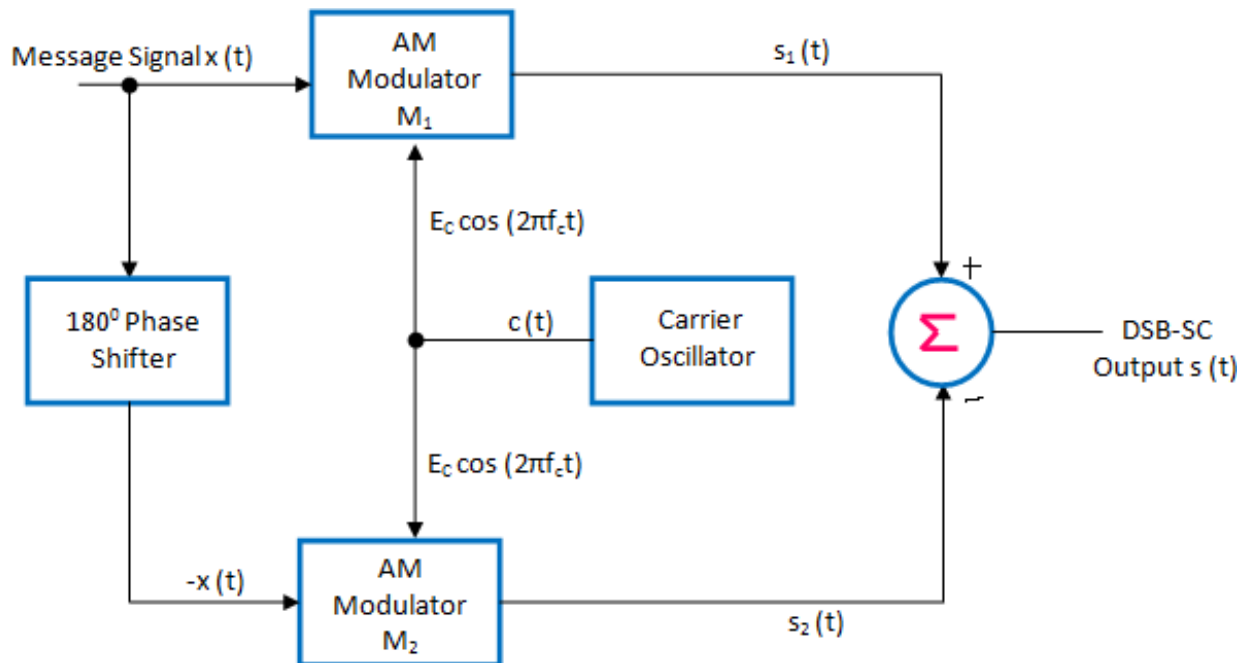

DSB-SC Modulation

Operation:

- Carrier $c(t)$ is applied to both the modulators.
- Message signal $x(t)$ is applied directly to modulator 1 and with a phase shift of 180° to modulator 2.

Output of modulator 1 is,

$$S_1(t) = A_c[1 + m_x(t)] \cos 2\pi f_c t \text{ ---(1)}$$

Output of modulator 2 is,

$$S_2(t) = A_c[1 - m_x(t)] \cos 2\pi f_c t \text{ ---(2)}$$

These two outputs are applied to subtractor, whose output is, $2m_x A_c \cos 2\pi f_c t$ ---(3)

DSB-SC Modulation

2. Ring Modulator:

It operates in two modes

- Mode 1: Without modulating signal $x(t)$
- Mode 2: With modulating signal $x(t)$

Mode 1: $c(t)$ is positive

- Diodes D1, D2 forward biased, D3, D4 Reverse biased
- Output of ring modulator will be zero.

$C(t)$ is negative

- Diodes D1, D2 reverse biased, D3, D4 forward biased
- Output of ring modulator will be zero.

Mode 2:

- When modulating signal is present, during positive half cycle D1, D2 will be ON and secondary of T1 is directly applied to primary of T2.
- Output will be positive
- During negative half cycle of modulating signal D3, D4 will be ON producing positive voltage.

DSB-SC Modulation

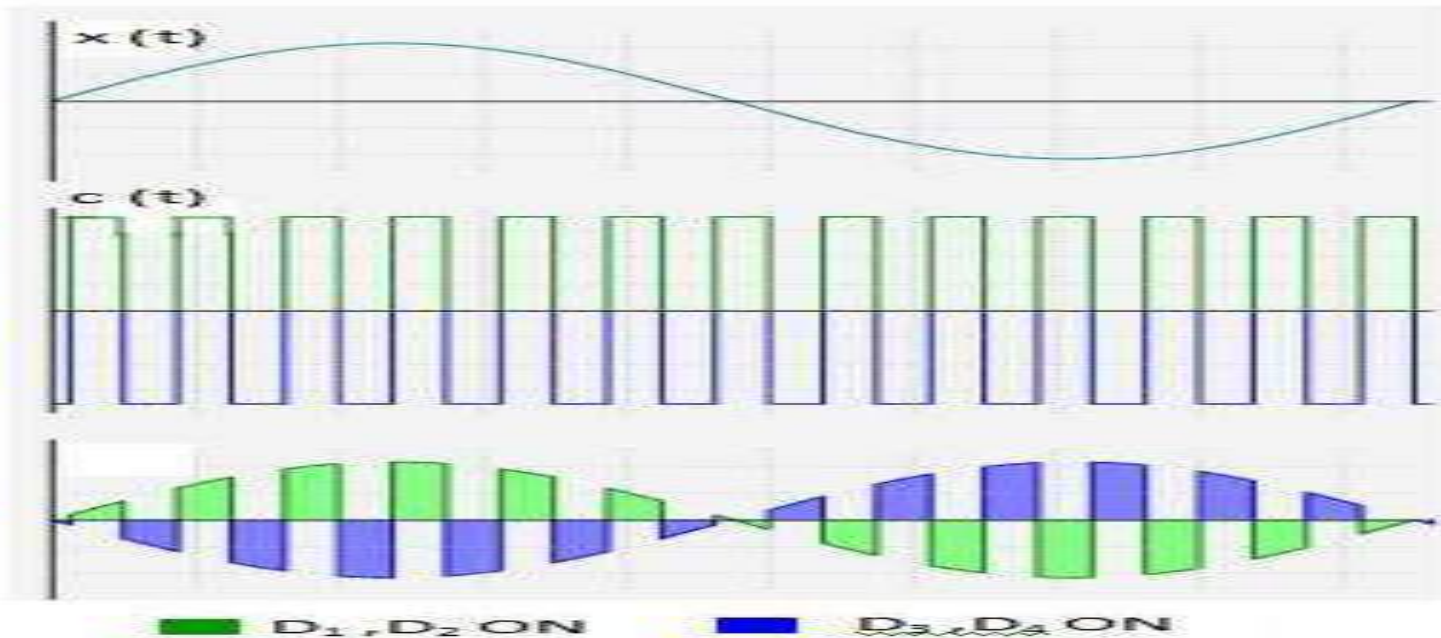
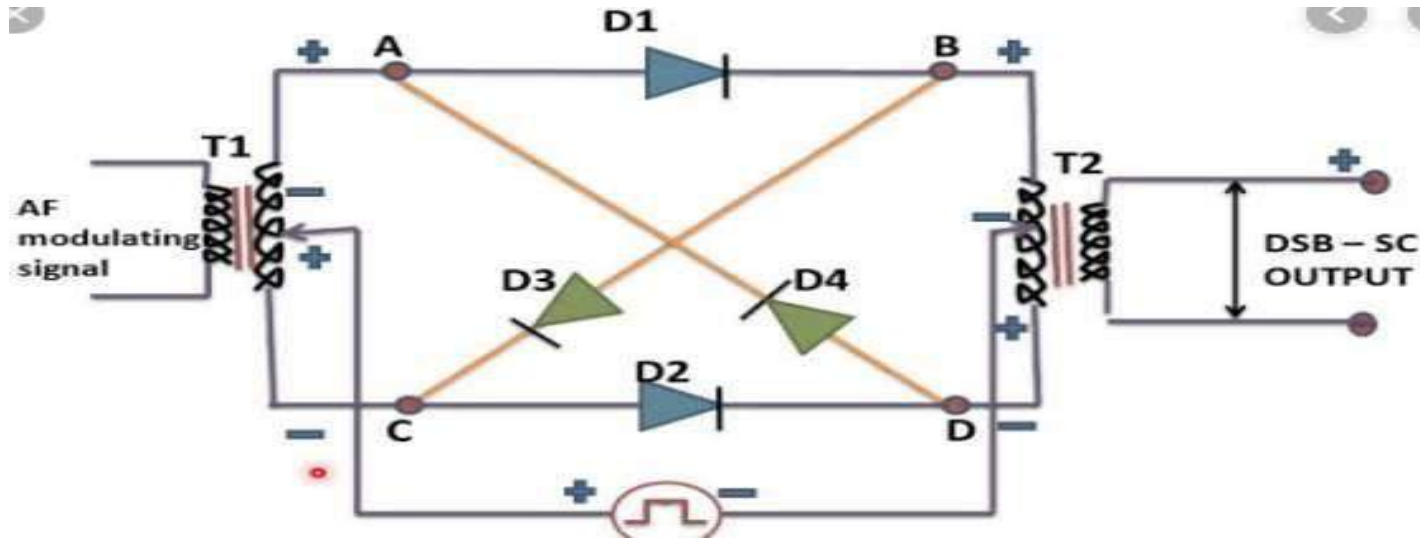

Time Domain representation of DSB-SC

Message signal is given by,

$$x(t) = A_m \cos(2\pi f_m t) \text{ ---(1)}$$

Carrier signal is given by,

$$C(t) = A_c \cos(2\pi f_c t) \text{ ---(2)}$$

DSB-SC modulated signal is given by,

$$S(t) = x(t) c(t) \text{ ---(3)}$$

$$S(t) = 1/2 A_m A_c [\cos 2\pi(f_c + f_m)t + \cos 2\pi(f_c - f_m)t] \text{ --(4)}$$

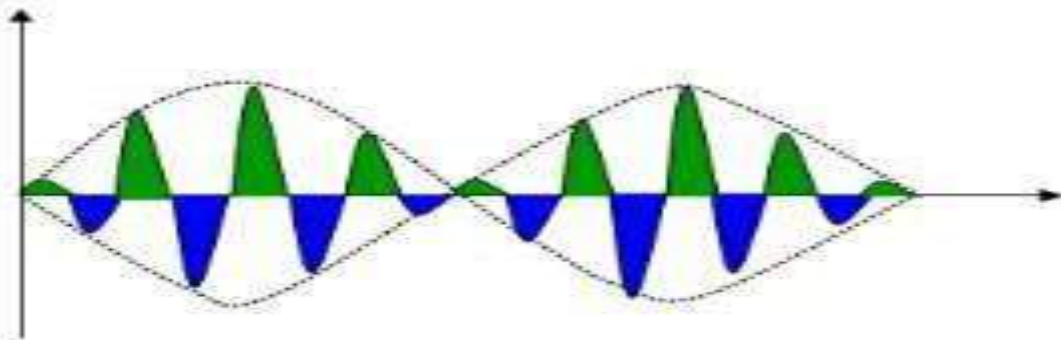

Frequency Domain representation

of DSB-SC

The frequency spectrum of DSB-SC is obtained by taking Fourier transform of $s(t)$

$$S(f) = F\{[1/2AmAc[\cos 2\pi(fc+fm)t + \cos 2\pi(fc-fm)t]]\}$$

$$S(f) = \frac{1}{4}AmAc[\delta(f + fc + fm) + \delta(f - fc - fm) + \delta(f + fc - fm) + \delta(f - fc + fm)]$$

This is the spectrum of DSB-SC wave.

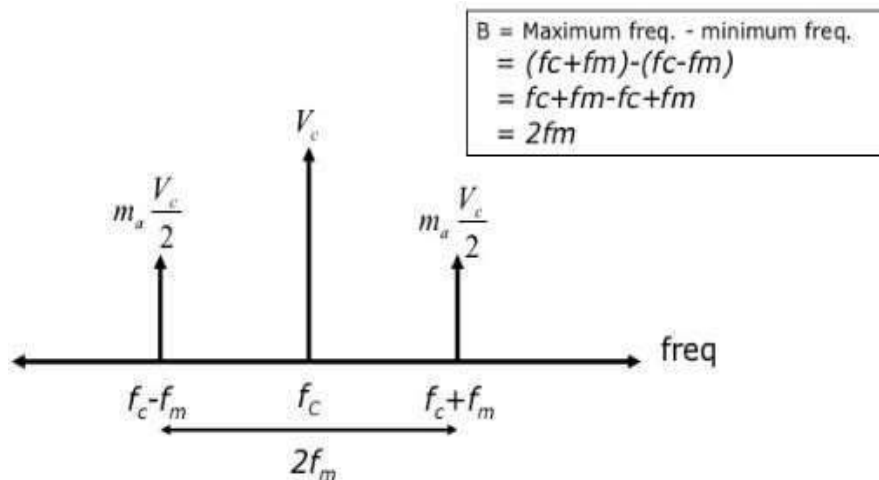

Demodulation of DSB-SC

Coherent Detection:

The modulating signal $x(t)$ is recovered from DSB-SC wave $s(t)$ by multiplying it with a locally generated carrier and then passing through a LPF.

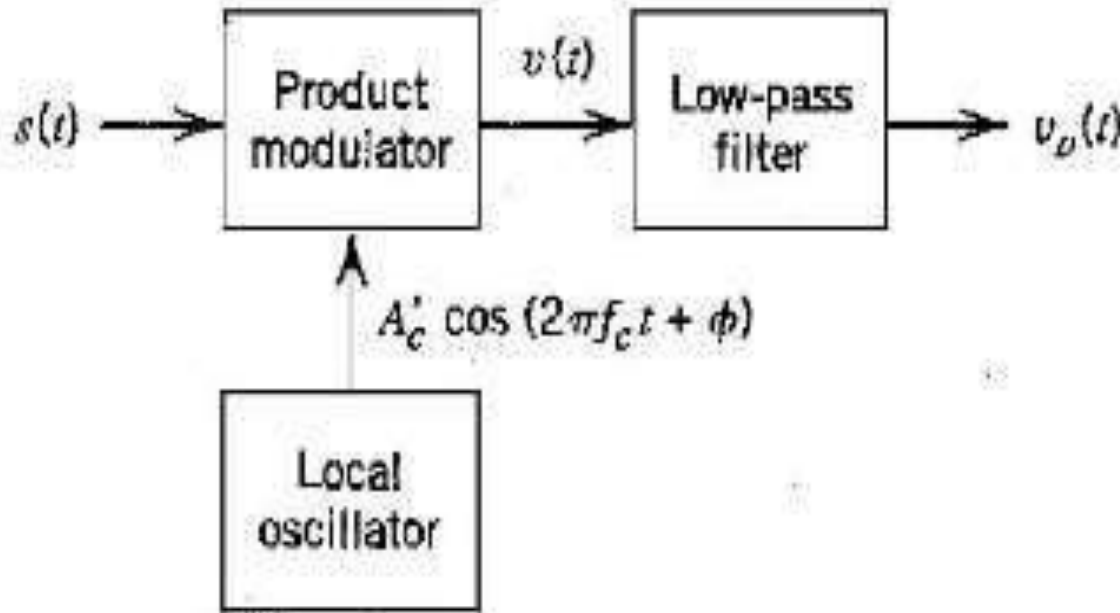

Demodulation of DSB-SC

$$V(t) = s(t) c(t) \text{ ---(1)}$$

Where,

$$S(t) = 1/2A_m A_c [\cos 2\pi(f_c + f_m)t + \cos 2\pi(f_c - f_m)t] \text{ ---(2)}$$

$$C(t) = \cos 2\pi f_c t \text{ ---(3)}$$

Substituting (2) & (3) in (1)

$$m(t) = \frac{1}{4} V_m V_c [\cos 2\pi(2f_c + f_m)t + \cos 2\pi f_m t \cos 2\pi(2f_c - f_m)t + \cos 2\pi f_m t]$$

When this is passed through a LPF,

$$V_0(t) = \frac{1}{4} V_m V_c \cos 2\pi f_m t$$

Single Sideband-Suppressed

Carrier(SSB-SC)

The modulation process in which only one side band is transmitted and with carrier suppression is called Single sideband suppressed carrier (SSB-SC).

Modulating Signal $m(t) = A_m \text{Cos}(2\pi f_m t)$ and Carrier Signal $c(t) = A_c \text{Cos}(2\pi f_c t)$

SSB-SC signal can be generated by passing DSB-SC signal through BPF. And DSB-SC signal is generated by multiplying $m(t)$ & $c(t)$.

$$A_{\text{SSB-SC}}(t) = \frac{A_m A_c}{2} \text{Cos}2\pi(f_c + f_m)t \text{ (or)}$$

$$A_{\text{SSB-SC}}(t) = \frac{A_m A_c}{2} \text{Cos}2\pi(f_c - f_m)t$$

Generation of SSB-SC

1. Filter or Frequency Discrimination Method:

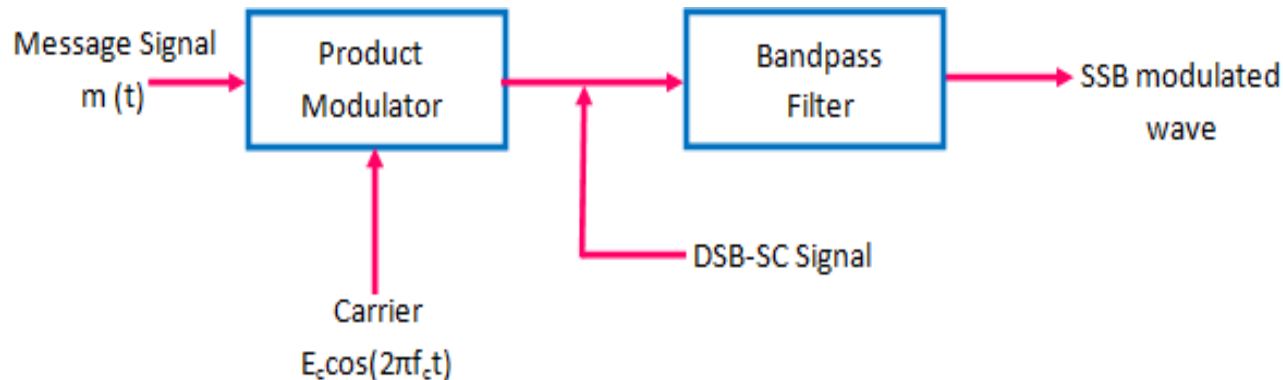

Filter method of generating DSB-SC Signal requires product modulator and BPF as shown in figure.

Here Product Modulator generates DSB-SC Signal which contains two side bands i.e USB & LSB.

By passing DSB-SC Signal through BPF either of sidebands are removed for generating SSB-SC Signal.

Generation of SSB-SC

2.Phase Shift or Phase Discrimination Method:

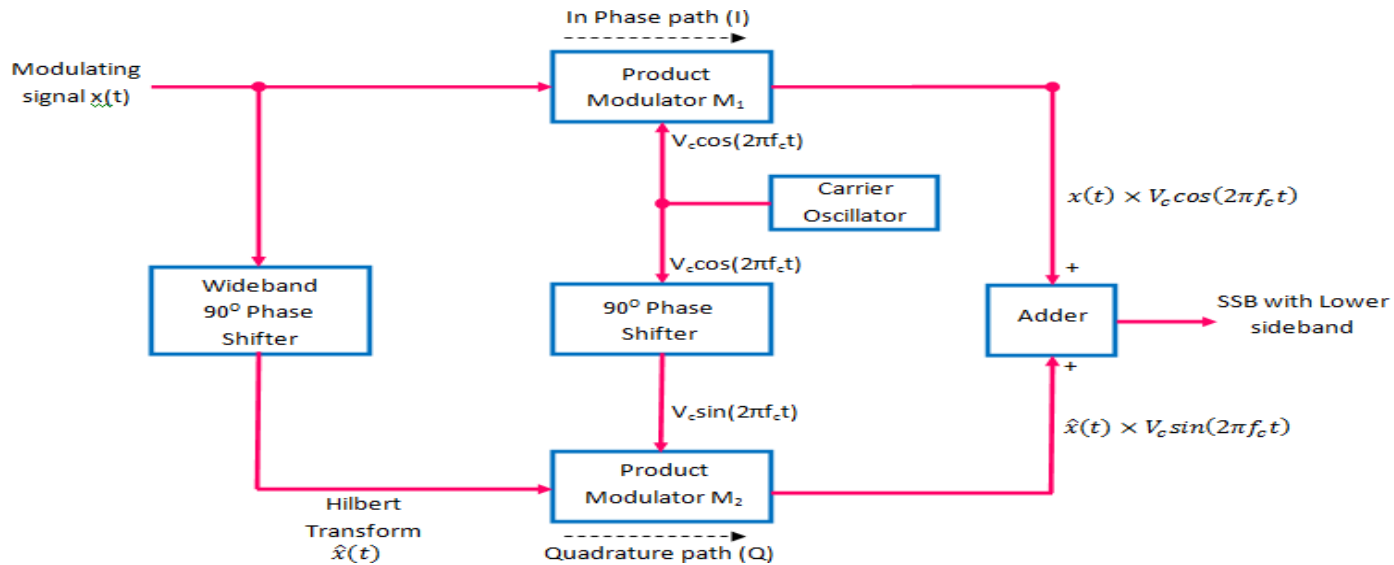

The figure shows the block diagram for the phase shift method of SSB generation and this system is used for the suppression of lower sideband.

This system uses two Product modulators M_1 and M_2 and two 90° phase shifting networks.

Vestigial Sideband Transmission

- VSB-SC is used to transmit Video Signal which is large BW signal containing very low and very high frequency components.
- Very low Frequencies raise sidebands near to carrier frequency.
- It is not possible to suppress one complete sideband.
- Very low frequencies contain most of useful information, any effect to complete suppress the one sideband would result phase distortion at these frequencies.
- Therefore compromise has been made to suppress the part of sideband. Hence VSB-SC Signal contain one full sideband & part of other side band.

Super Heterodyne AM Receiver

Heterodyne means mixing two frequencies and generating single or constant frequency and the output of mixer will be fixed frequency.

Specification of AM Receiver:

- The frequency range of AM-MW(Medium wave)
: (540-1640) KHz
- Band width of receiver: $1640 \text{ KHz} - 540 \text{ KHz} = 1100 \text{ KHz}$
- Band width of each AM station : 10 KHz
- No. of stations available: 110
- Intermediate frequency (f_{IF}): 455 KHz

Super Heterodyne AM Receiver

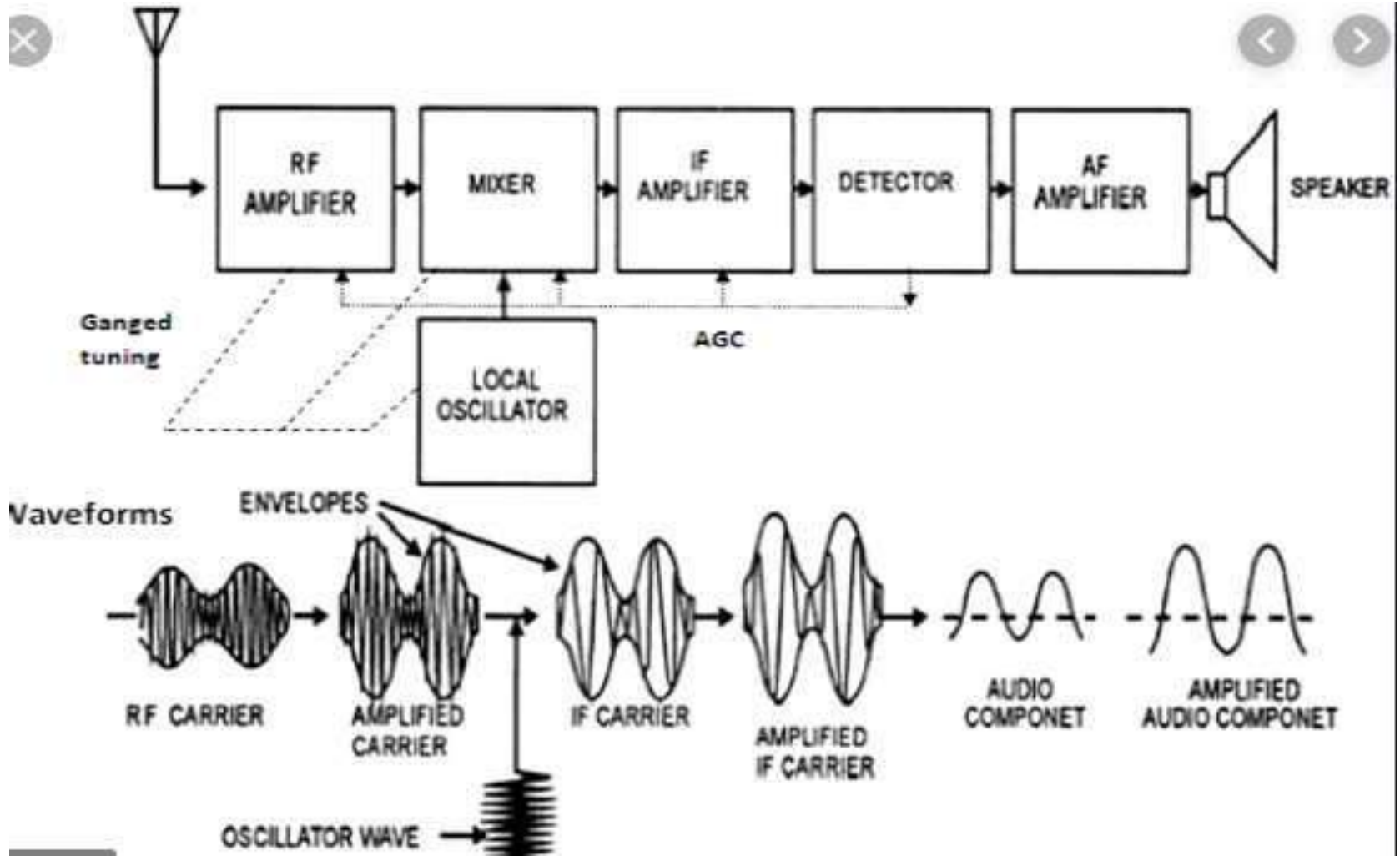

Super Heterodyne AM Receiver

Antenna: It is passive device which converts electromagnetic signal into electrical signal.

RF Tuned Amplifier:

- It is broad band amplifier which contain tuning circuit and amplifier.
- Tuning circuit designed to select 110 stations and amplifier provides amplification for 1100 KHz band width.
- RF tuned amplifier is responsible for sensitivity, selectivity, Image signal rejection and noise reduction.

Mixer:

- It is combination of frequency mixer and Band Pass Filter (BPF).
- Frequency generates sum and difference frequency of incoming signal and locally generated signal.
- BPF selects difference frequency at the output whose center frequency is equal to= 455 KHz.

Local Oscillator:

- It is either Colpits or Hartley oscillator.
- It generates carrier frequency 455 KHz greater than the incoming carrier frequency to produce constant or fixed frequency.

Super Heterodyne AM Receiver

IF Amplifier:

- It is narrow band, high gain and fixed frequency amplifier which provides amplification for 10 KHz band width at center frequency of 455 KHz.
- It is cascade CE amplifier which provides 90% of total receiver amplification.

Detector or Demodulator:

- It is frequency translator circuit which extracts modulating signal from AM signal.
- Usually Envelope detector is used.
- Fidelity of the receiver is mainly depends on detector or demodulator.

Audio Amplifier:

- It is low frequency amplifier which provides amplification at (20- 20K) Hz.
- It contain cascade CE Voltage amplifier followed by Power amplifier.

Loud Speaker:

- It converts Electrical signal into sound or audio signal.

ANGLE MODULATION

Angle modulation is a process of varying angle of the carrier in accordance with the instantaneous values of modulating signal.

Angle can be varied by varying frequency or phase.

Angle modulation is of 2 types.

- **Frequency Modulation**
- **Phase Modulation**

Frequency Modulation

The process of varying frequency of the carrier in accordance with the instantaneous values of the modulating signal.

Relation between angle and frequency :

Consider carrier signal $c(t) = A_c \cos(\omega_c t + \phi)$
 $= A_c \cos(2\pi f_c t + \phi)$

Where, $\omega_c =$ Carrier frequency

$\phi =$ Phase

$C(t) = A_c \cos[\psi(t)]$, where, $\psi(t) = \omega_c t + \phi$

$$\frac{d}{dt} \psi(t) = \omega_c$$

i.e Frequency can be obtained by derivating angle and angle can be obtained by integrating frequency.

Frequency Modulation

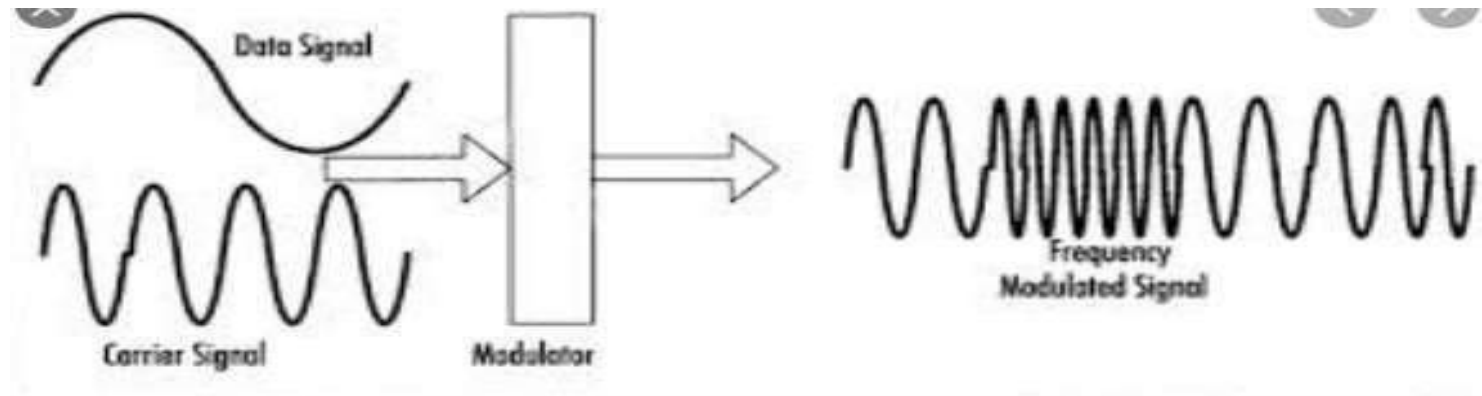

Frequency modulator converts input voltage into frequency i.e the amplitude of modulating signal $m(t)$ changes to frequency at the output.

Consider carrier signal $c(t) = A_c \cos \omega_c t$

The frequency variation at the output is called instantaneous frequency and is expressed as,

$$\omega_i = \omega_c + k_f m(t)$$

Where, k_f = frequency sensitivity factor in Hz/volt

Frequency Modulation

The angle of the carrier after modulation can be written as,

$$\psi_i(t) = \int \omega_i dt = \int [\omega_c + k_f m(t)] dt$$

$$\psi_i(t) = \omega_c t + k_f \int m(t) dt$$

Frequency modulated signal can be written as,

$$A_{FM}(t) = A_c \cos [\psi_i(t)] = A_c \cos [\omega_c t + k_f \int m(t) dt]$$

Frequency Deviation in FM:

The instantaneous frequency, $\omega_i = \omega_c + k_f m(t)$
 $= \omega_c + \Delta\omega$

Where, $\Delta\omega = k_f m(t)$ is called frequency deviation which may be positive or negative depending on the sign of $m(t)$.

Phase Modulation

The process of varying the phase of carrier in accordance with instantaneous values of the modulating signal.

Consider modulating signal $x(t)$ and carrier signal $c(t) = A_c \cos wct$

Phase modulating signal,

$$A_{PM}(t) = A_c \cos[\psi_i(t)]$$

Where, $\psi_i(t) = wct + k_p m(t)$

Where, $k_p =$ Phase sensitivity factor in rad/volt

$$A_{PM}(t) = A_c \cos[wct + k_p m(t)]$$

Phase Modulation

Frequency deviation in PM:

$$\begin{aligned}\omega_i &= \frac{d}{dt} \psi_i(t) = \frac{d}{dt} [\omega_c t + k_p m(t)] \\ &= \omega_c + k_p \frac{d}{dt} m(t) \\ &= \omega_c + \Delta\omega\end{aligned}$$

Where, $\Delta\omega$ = Frequency deviation = $k_p \frac{d}{dt} m(t)$

Conversion between Frequency and Phase Modulation:

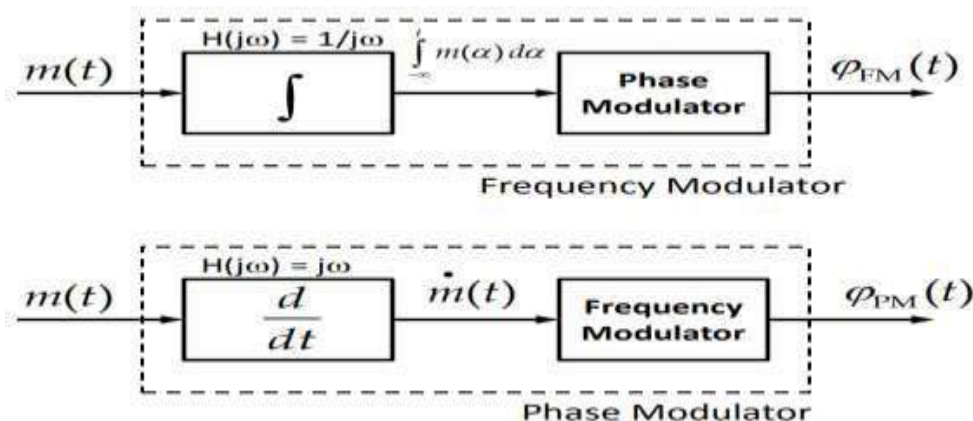

Modulation Index

Definition:

Modulation Index is defined as the ratio of frequency deviation (δ) to the modulating frequency (f_m).

$$\text{M.I.} = \frac{\text{Frequency Deviation}}{\text{Modulating Frequency}}$$

$$mf = \frac{\delta}{f_m}$$

In FM M.I. > 1

Modulation Index of FM decides –

- (i) Bandwidth of the FM wave.**
- (ii) Number of sidebands in FM wave.**

Deviation Ratio

The modulation index corresponding to maximum deviation and maximum modulating frequency is called deviation ratio.

$$\begin{aligned}\text{Deviation Ratio} &= \frac{\text{Maximum Deviation}}{\text{Maximum modulating Frequency}} \\ &= \frac{\delta_{\max}}{f_{\max}}\end{aligned}$$

In FM broadcasting the maximum value of deviation is limited to **75 kHz**. The maximum modulating frequency is also limited to **15 kHz**.

Percentage M.I. of FM

The percentage modulation is defined as the ratio of the actual frequency deviation produced by the modulating signal to the maximum allowable frequency deviation.

$$\% \text{ M.I.} = \frac{\text{Actual deviation}}{\text{Maximum allowable deviation}}$$

Mathematical Representation of FM

(i) Modulating Signal:

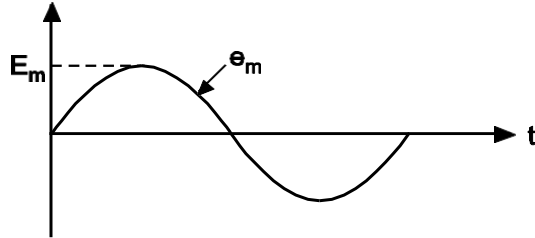

It may be represented as,

$$e_m = E_m \cos \omega_m t \quad \dots(1)$$

Here cos term taken for simplicity

where,

e_m = Instantaneous amplitude

ω_m = Angular velocity

= $2\pi f_m$

f_m = Modulating frequency

(ii) Carrier Signal:

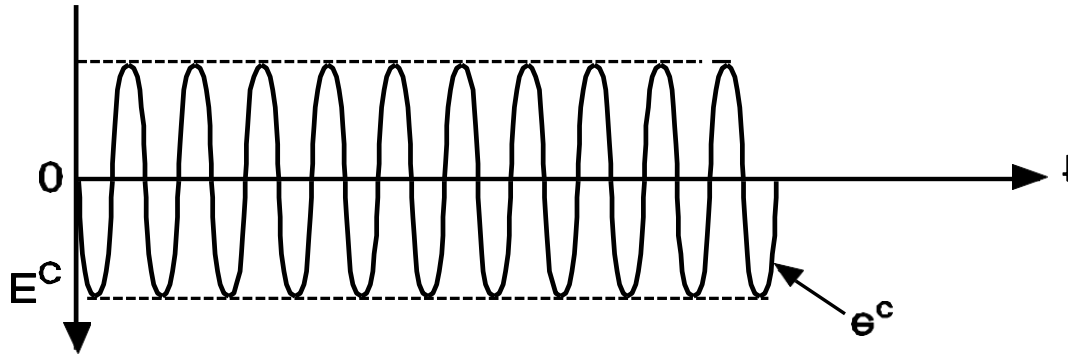

Carrier may be represented as,

$$e_c = E_c \sin (\omega_{ct} + \phi) \quad \text{-----(2)}$$

where,

e_c = Instantaneous amplitude

ω_c = Angular velocity

= $2\pi f_c$

f_c = Carrier frequency

ϕ = Phase angle

(iii) FM Wave:

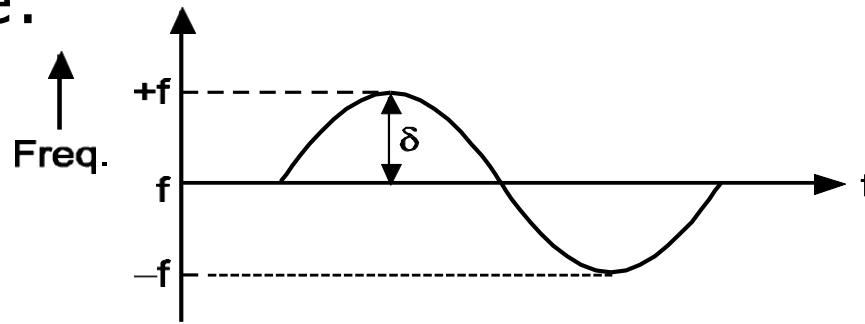

Fig. Frequency Vs. Time in FM

FM is nothing but a deviation of frequency.

From Fig. 2.25, it is seen that instantaneous frequency 'f' of the FM wave is given by,

$$\mathbf{f = f_c (1 + K E_m \cos \omega_m t) \dots (3)}$$

where,

f_c = Unmodulated carrier frequency

K = Proportionality constant

$E_m \cos \omega_m t$ = Instantaneous modulating signal

(Cosine term preferred for simplicity otherwise we can use sine term also)

- The maximum deviation for this particular signal will occur, when $\cos \omega_m t = \pm 1$ i.e. maximum.

∴ Equation (2.26) becomes,

$$\mathbf{f = f_c (1 \pm K E_m) \dots (4)}$$

$$\mathbf{\therefore f = f_c \pm K E_m f_c \dots (5)}$$

So that maximum deviation δ will be given by,

$$\delta = K E_m f_c \dots (6)$$

The instantaneous amplitude of FM signal is given by,

$$e_{FM} = A \sin [f(\omega_c, \omega_m)]$$

$$= A \sin \theta \dots (7)$$

where,

$$f(\omega_c, \omega_m) = \text{Some function of carrier and modulating}$$

frequencies

Let us write equation (2.26) in terms of ω as,

$$\omega = \omega_c (1 + K E_m \cos \omega_m t)$$

To find θ , ω must be integrated with respect to time.

Thus,

$$\theta = \int \omega dt$$

$$= \int \omega_c (1 + K E_m \cos \omega_m t) dt$$

$$\theta = \omega_c \int (1 + K E_m \cos \omega_m t) dt$$

$$= \omega_c \left(t + K E_m \frac{\sin \omega_m t}{\omega_m} \right)$$

$$= \omega_c t + K E_m \omega_c \frac{\sin \omega_m t}{\omega_m}$$

$$= \omega_c t + K E_m f_c \frac{\sin \omega_m t}{\omega_m}$$

$$= \omega_c t + \frac{\delta \sin \omega_m t}{f_m} \quad [\because \delta = K E_m f_c]$$

\therefore

Substitute value of θ in equation (7)

Thus,

$$e_{FM} = A \sin \left(\omega_c t + \frac{\delta \sin \omega_m t}{f_m} \right) \text{---(8)}$$

$$e_{FM} = A \sin \left(\omega_c t + mf \sin \omega_m t \right) \text{---(9)}$$

This is the equation of FM.

Frequency Spectrum of FM

Frequency spectrum is a graph of amplitude versus frequency.

The frequency spectrum of FM wave tells us about number of sideband present in the FM wave and their amplitudes.

The expression for FM wave is not simple. It is complex because it is sine of sine function.

Only solution is to use '**Bessels Function**'.

Equation (2.32) may be expanded as,

$$e_{FM} = \left\{ \begin{aligned} &A J_0(m_f) \sin \omega_c t \\ &+ J_1(m_f) [\sin(\omega_c + \omega_m) t - \sin(\omega_c - \omega_m) t] \\ &+ J_1(m_f) [\sin(\omega_c + 2\omega_m) t + \sin(\omega_c - 2\omega_m) t] \\ &+ J_3(m_f) [\sin(\omega_c + 3\omega_m) t - \sin(\omega_c - 3\omega_m) t] \\ &+ J_4(m_f) [\sin(\omega_c + 4\omega_m) t + \sin(\omega_c - 4\omega_m) t] \\ &+ \dots \dots \dots \end{aligned} \right\} \dots (2.33)$$

From this equation it is seen that the FM wave consists of:

(i) Carrier (First term in equation).

(ii) Infinite number of sidebands (All terms except first term are sidebands).

The amplitudes of carrier and sidebands depend on 'J' coefficient.

$$\omega_c = 2\pi f_c, \quad \omega_m = 2\pi f_m$$

So in place of ω_c and ω_m , we can use f_c and f_m .

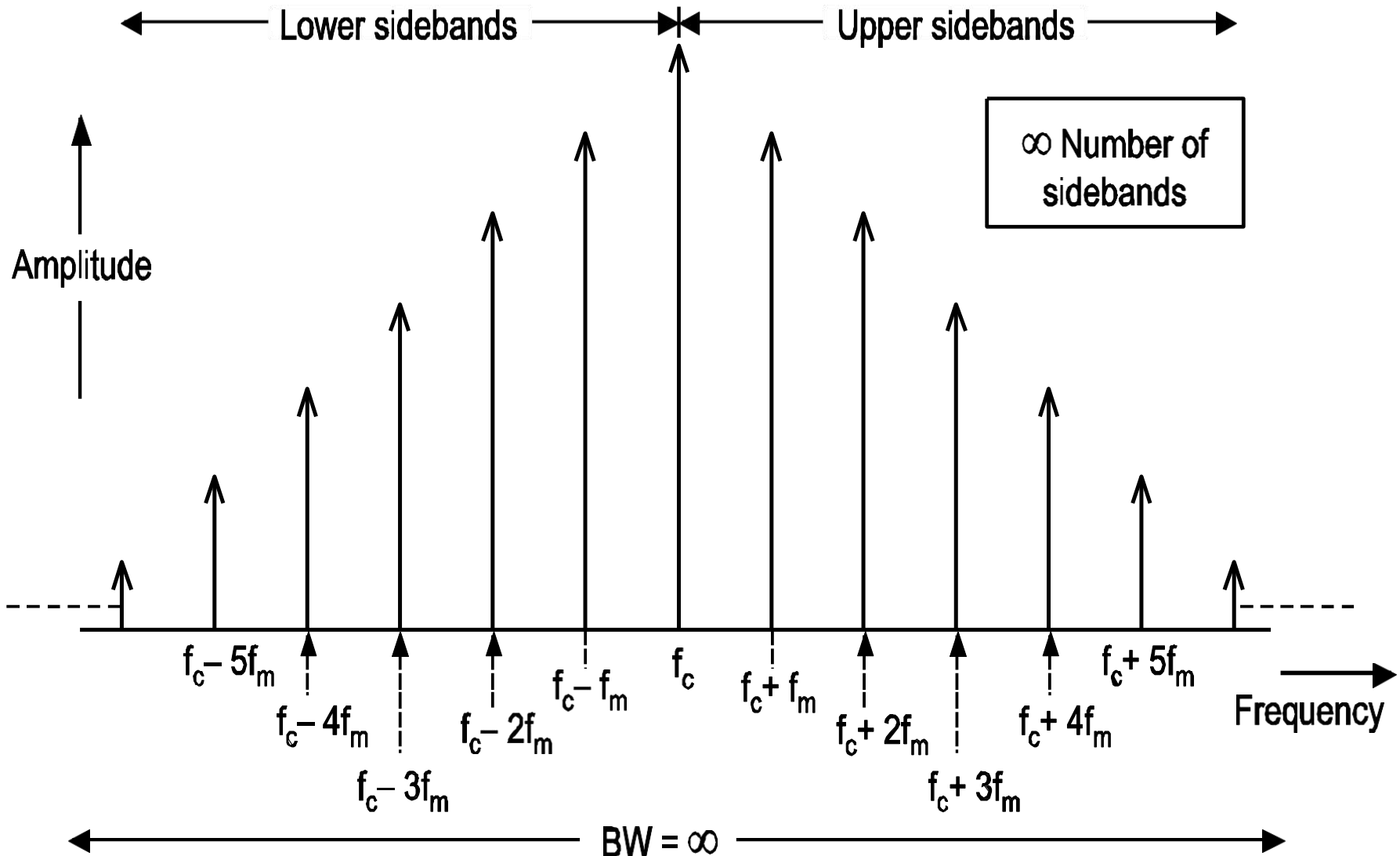

Fig. : Ideal Frequency Spectrum of FM

Bandwidth of FM

From frequency spectrum of FM wave shown in Fig. 2.26, we can say that the bandwidth of FM wave is infinite.

But practically, it is calculated based on how many sidebands have significant amplitudes.

(i) The Simple Method to calculate the bandwidth is –

$$\text{BW} = 2f_m \times \text{Number of significant sidebands} \quad \text{--(1)}$$

With increase in modulation index, the number of significant sidebands increases. So that bandwidth also increases.

(ii) The second method to calculate bandwidth is by **Carson's rule.**

Carson's rule states that, the bandwidth of FM wave is twice the sum of deviation and highest modulating frequency.

$$BW = 2(\delta + f_{m\max}) \quad \dots(2)$$

Highest order side band = To be found from table 2.1 after the calculation of modulation Index m where, $m = \delta/f_m$

e.g. If $m = 20\text{KHZ}/5\text{KHZ}$

From table, for modulation index 4, highest order side band is 7th.

Therefore, the bandwidth is

$$\begin{aligned} \text{B.W.} &= 2 f_m \times \text{Highest order side band} \\ &= 2 \times 5 \text{ kHz} \times 7 \\ &= 70 \text{ kHz} \end{aligned}$$

Types of Frequency Modulation

FM (Frequency Modulation)

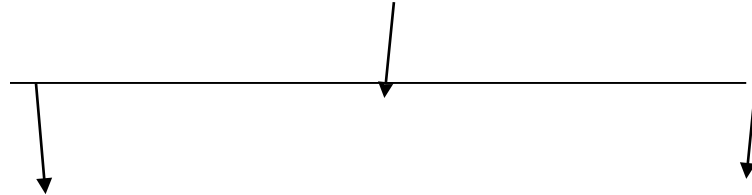

Narrowband
FM (NBFM)

[When modulation index is small]

Wideband FM
(WBFM)

[When modulation index is large]

Comparison between Narrowband and Wideband FM

Sr. No.	Parameter	NBFM	WBFM
1.	Modulation index	Less than or slightly greater than 1	Greater than 1
2.	Maximum deviation	5 kHz	75 kHz
3.	Range of modulating frequency	20 Hz to 3 kHz	20 Hz to 15 kHz
4.	Maximum modulation index	Slightly greater than 1	5 to 2500
5.	Bandwidth	Small approximately same as that of AM $BW = 2f_m$	Large about 15 times greater than that of NBFM. $BW = 2(\delta + f_{mmax})$
6.	Applications	FM mobile communication like police wireless, ambulance, short range ship to shore communication etc.	Entertainment broadcasting (can be used for high quality music transmission)

Representation of FM

FM can be represented by two ways:

1. Time domain.
2. Frequency domain.

1. FM in Time Domain

Time domain representation means continuous variation of voltage with respect to time as shown in Fig.

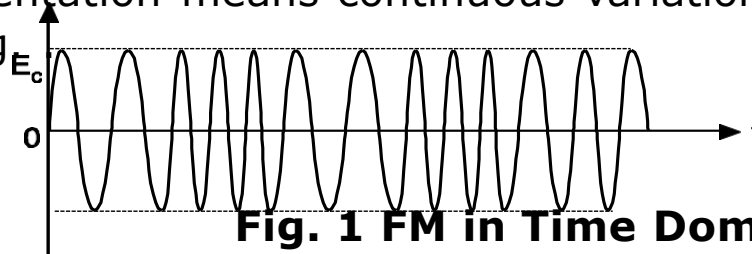

Fig. 1 FM in Time Domain

2. FM in Frequency Domain

- Frequency domain is also known as **frequency spectrum**.
- FM in frequency domain means graph or plot of amplitude versus frequency as shown in Fig. 2.29.

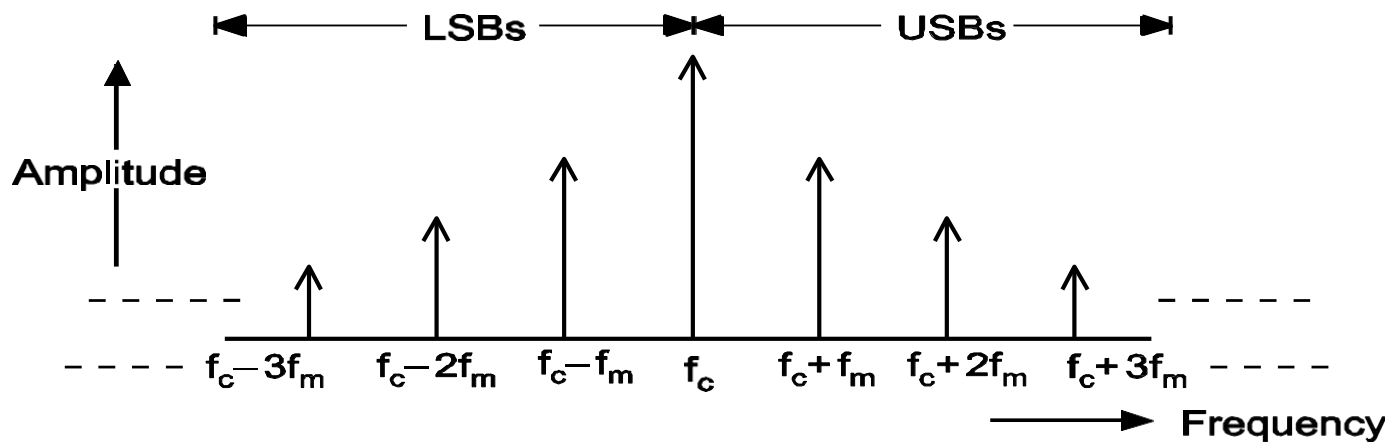

Fig. 2: FM in Frequency Domain

Pre-emphasis and De-emphasis

- Pre and de-emphasis circuits are used only in frequency modulation.
 - Pre-emphasis is used **at transmitter** and de-emphasis **at receiver**.

1. Pre-emphasis

- In FM, the noise has a greater effect on the higher modulating frequencies.
- This effect can be reduced by increasing the value of modulation index (m_f), for higher modulating frequencies.
- This can be done by increasing the deviation ' δ ' and ' δ ' can be increased by increasing the amplitude of modulating signal at higher frequencies.

Definition:

The artificial boosting of higher audio modulating frequencies in accordance with prearranged response curve is called pre-emphasis.

- Pre-emphasis circuit is a high pass filter as shown in Fig.

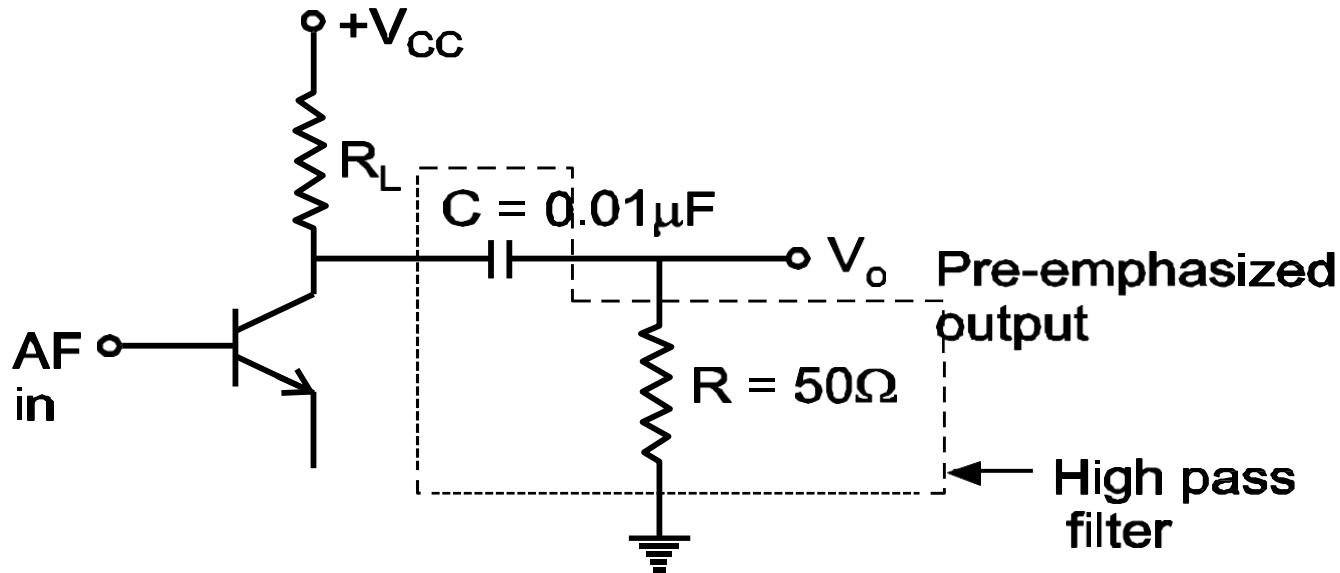

As shown in Fig. 1, AF is passed through a high-pass filter, before applying to FM modulator.

- As modulating frequency (f_m) increases, capacitive reactance decreases and modulating voltage goes on increasing.

$f_m \propto$ Voltage of modulating signal applied to FM modulator
Boosting is done according to pre-arranged curve as shown

in Fig. 2.

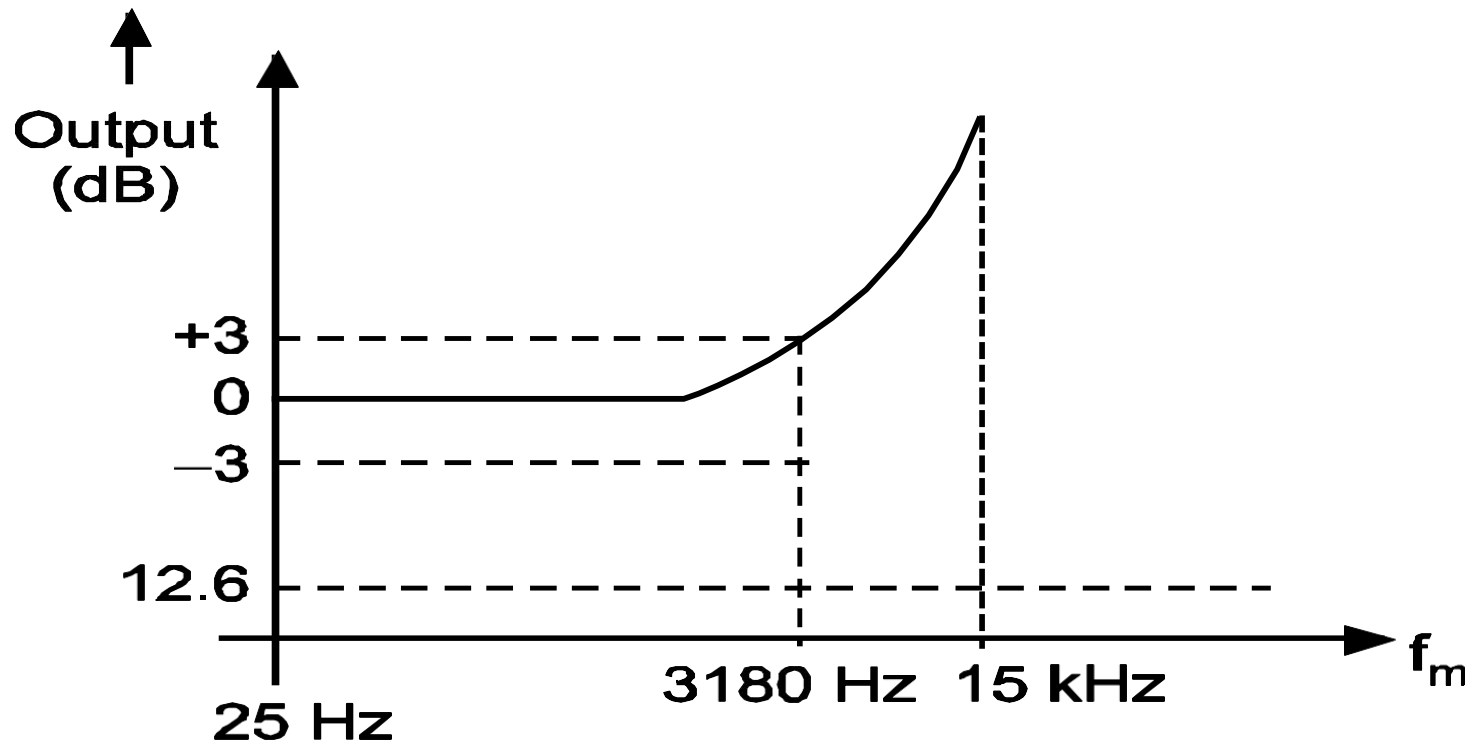

Fig. 2: P re-emphasis Curve

- The time constant of pre-emphasis is at $50\ \mu\text{s}$ in all CCIR standards.
 - In systems employing American FM and TV standards, networks having time constant of $75\ \mu\text{sec}$ are used.
 - **The pre-emphasis is used at FM transmitter** as shown in Fig.

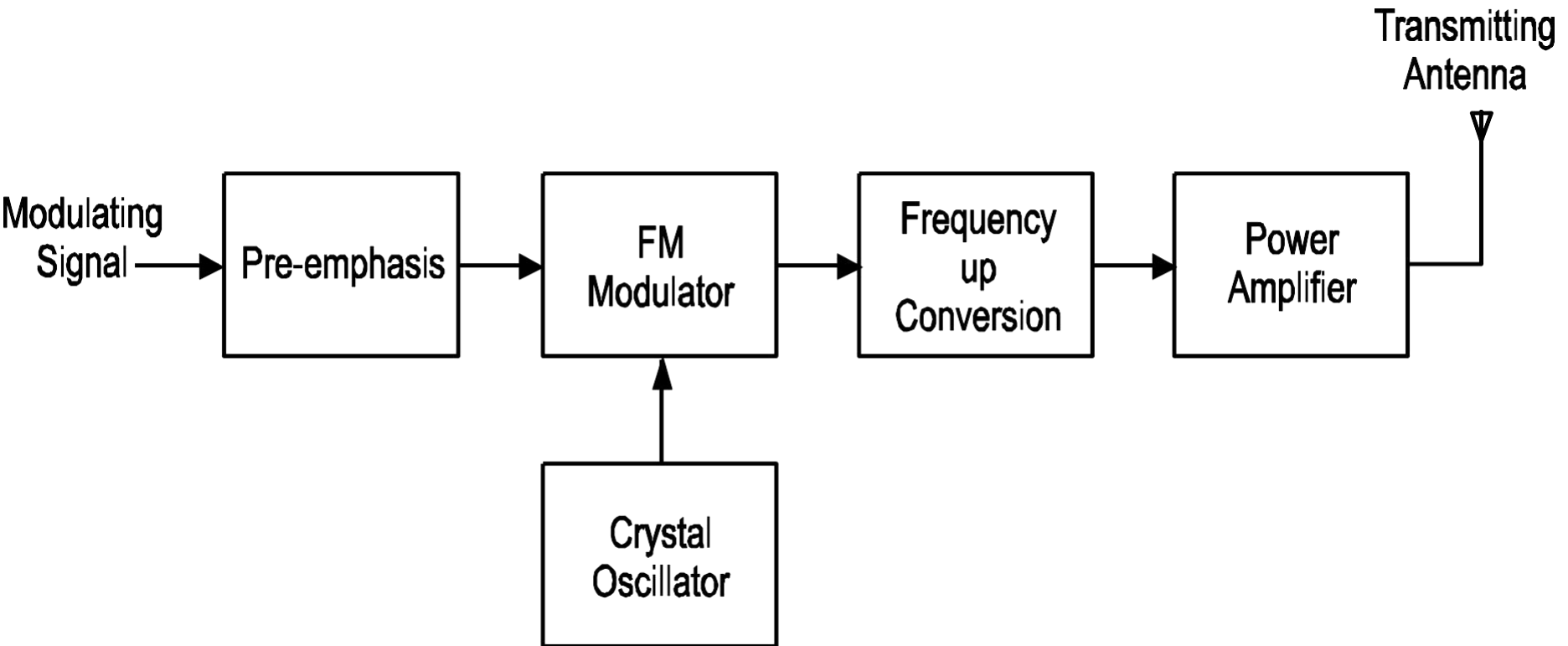

Fig. FM Transmitter with Pre-emphasis

De-emphasis

- De-emphasis circuit is **used at FM receiver**.

Definition:

The artificial boosting of higher modulating frequencies in the process of pre-emphasis is nullified at receiver by process called **de-emphasis**.

- De-emphasis circuit is a low pass filter shown in Fig.

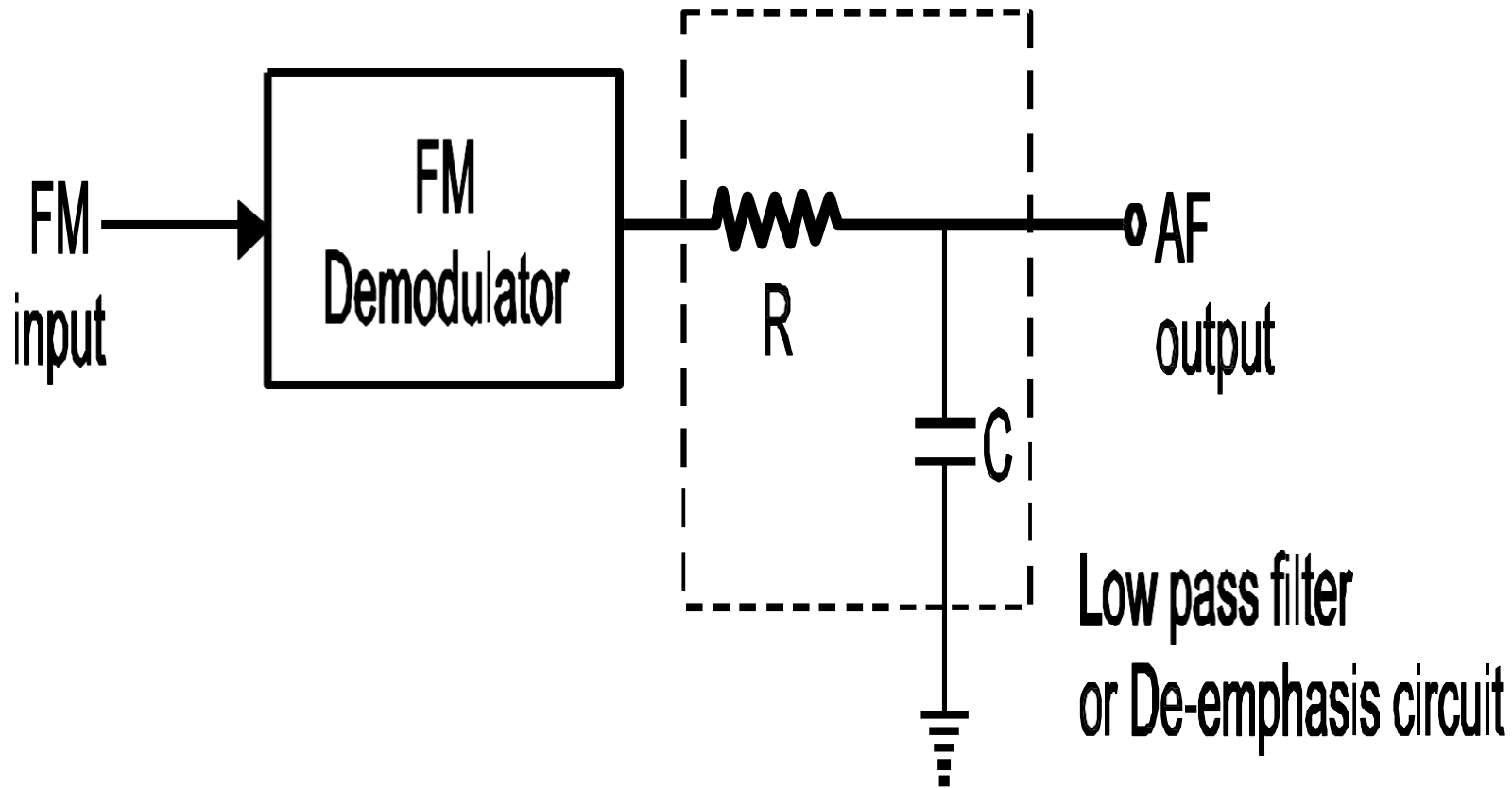
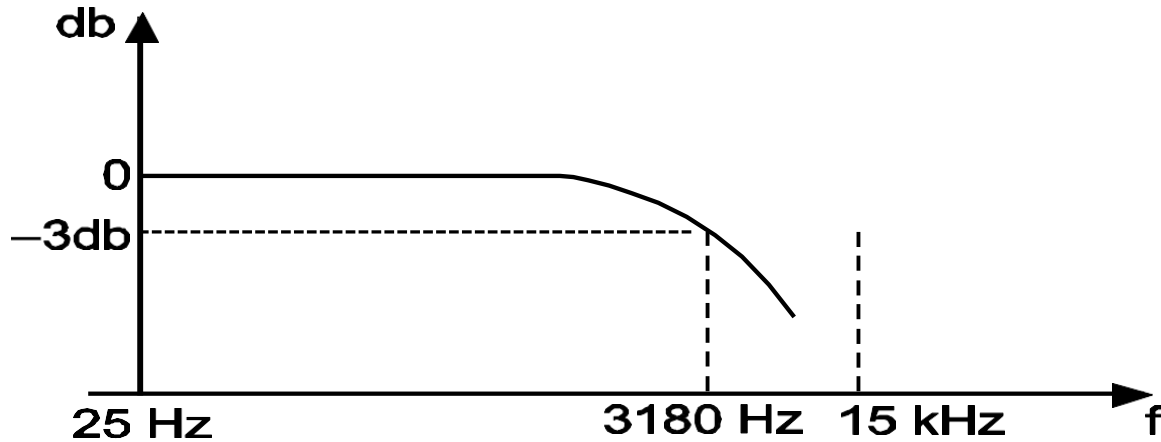

Fig. De-emphasis Circuit

Fig. De-emphasis Curve



As shown in Fig.5, de-modulated FM is applied to the de-emphasis circuit (low pass filter) where with increase in f_m , capacitive reactance X_c decreases. So that output of de-emphasis circuit also reduces •

Fig. 5 shows the de-emphasis curve corresponding to a time constant

$50 \mu s$. A $50 \mu s$ de-emphasis corresponds to a frequency response curve that is 3 dB down at frequency given by,

$$\begin{aligned} f &= 1/2\pi RC \\ &= 1/2\pi \times 50 \times 1000 \\ &= 3180 \text{ Hz} \end{aligned}$$

Comparison between Pre-emphasis and De-emphasis

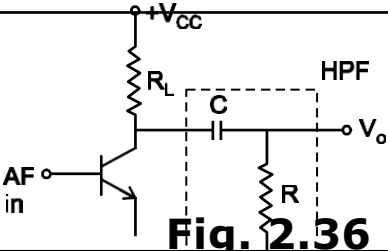
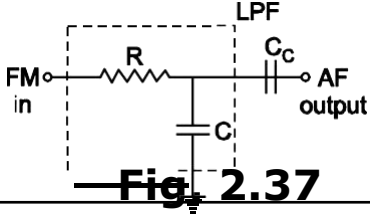
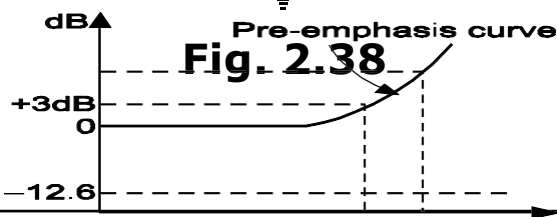
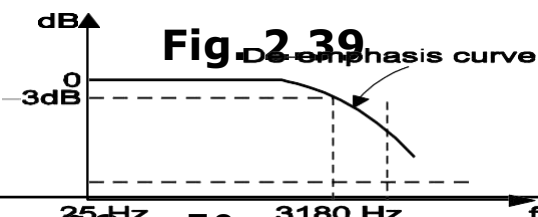
Parameter	Pre-emphasis	De-emphasis
1. Circuit used	High pass filter.	Low pass filter.
2. Circuit diagram	 <p>Fig. 2.36</p>	 <p>Fig. 2.37</p>
3. Response curve	 <p>Fig. 2.38</p>	 <p>Fig. 2.39</p>
4. Time constant	$T = RC = 50 \mu\text{s}$	$T = RC = 50 \mu\text{s}$
5. Definition	Boosting of higher frequencies	Removal of higher frequencies
6. Used at	FM transmitter	FM receiver.

Comparison between AM and FM

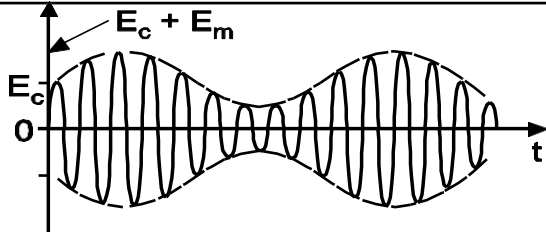
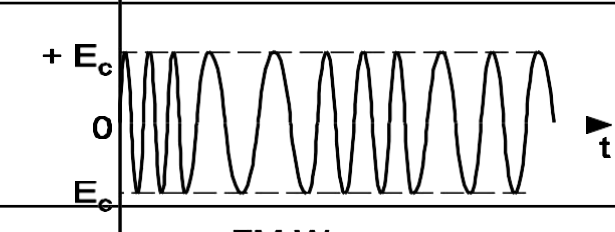
Parameter	AM	FM
1. Definition	Amplitude of carrier is varied in accordance with amplitude of modulating signal keeping frequency and phase constant.	Frequency of carrier is varied in accordance with the amplitude of modulating signal keeping amplitude and phase constant.
2. Constant parameters	Frequency and phase.	Amplitude and phase.
3. Modulated signal	 <p style="text-align: center;">AM Wave</p>	 <p style="text-align: center;">FM Wave</p>
4. Modulation Index	$m = E_m / E_c$	$m = \delta / f_m$
5. Number of sidebands	Only two	Infinite and depends on m_f .
6. Bandwidth	$BW = 2f_m$	$BW = 2(\delta + f_{m(max)})$
7. Application	MW, SW band broadcasting, video transmission in TV.	Broadcasting FM, audio transmission in TV.

FM GENERATION

There are two methods for generation of FM wave.

Generation of FM

Direct Method

1. Reactance Modulator
2. Varactor Diode

Indirect Method

1. Armstrong Method

Reactance Method

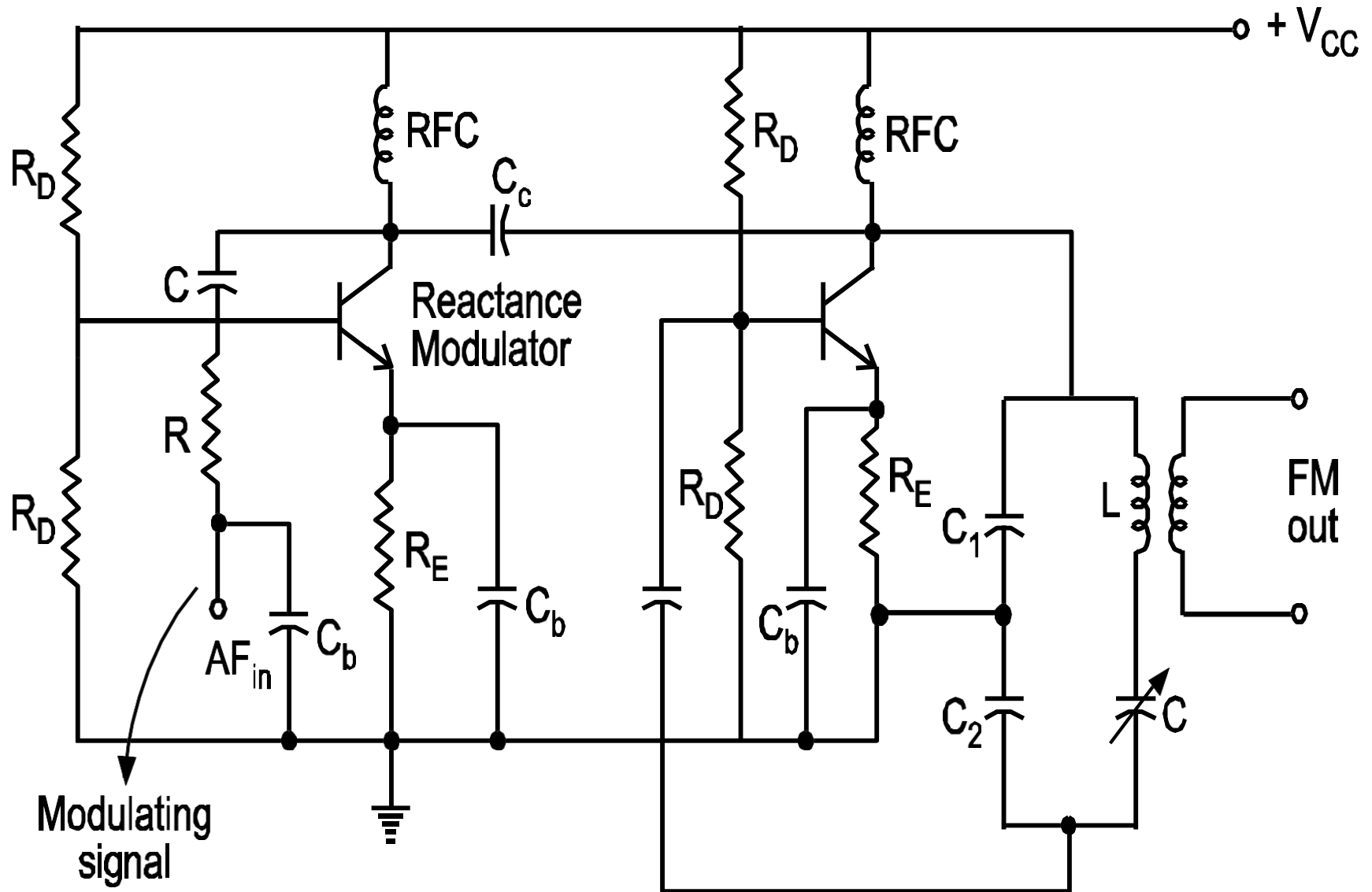

Fig. : Transistorized Reactance Modulator

Varactor Diode Modulator

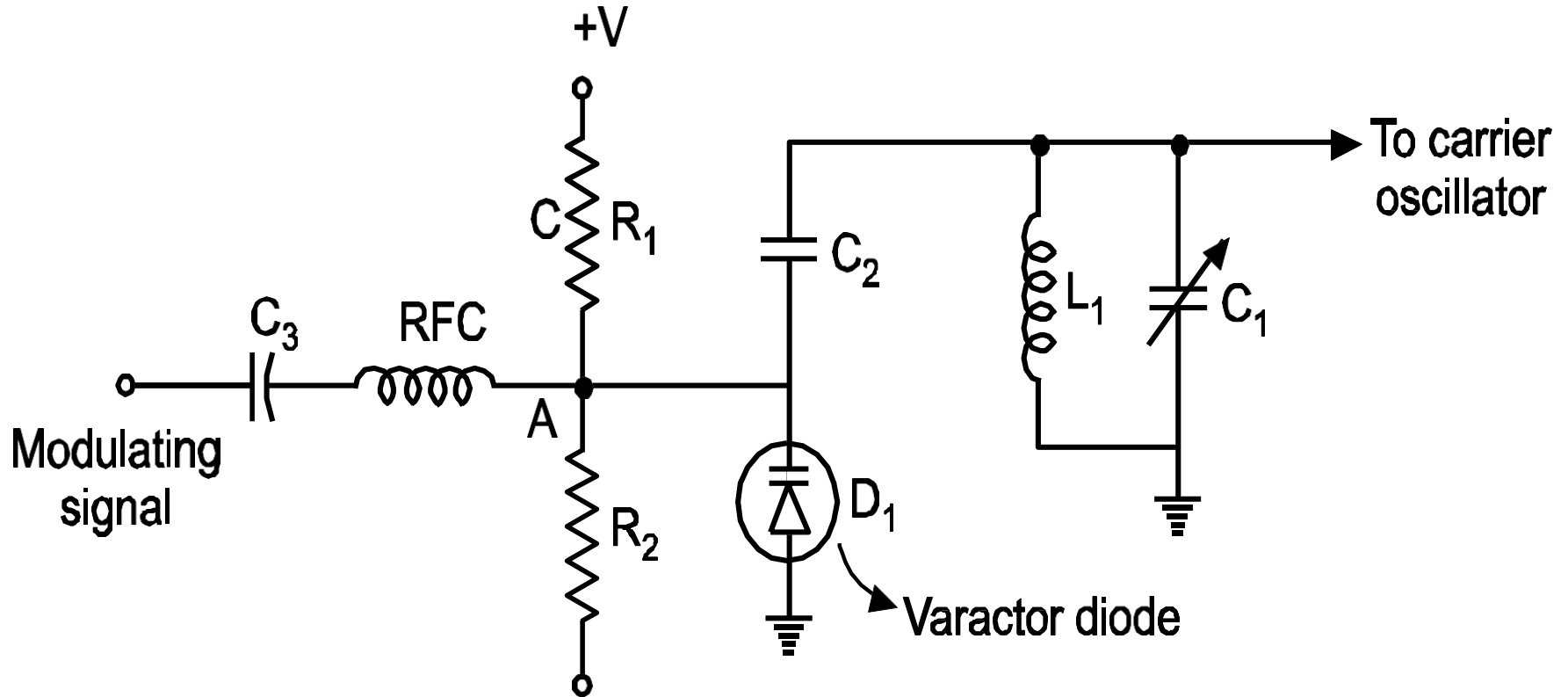

Fig. : Varactor Diode Frequency Modulator

Limitations of Direct Method of FM Generation

1. In this method, it is very difficult to get high order stability in carrier frequency because in this method the basic oscillator is not a stable oscillator, as it is controlled by the modulating signal.

2. Generally in this method we get distorted FM, due to non-linearity of the varactor diode.

FM Transmitter (Armstrong Method)

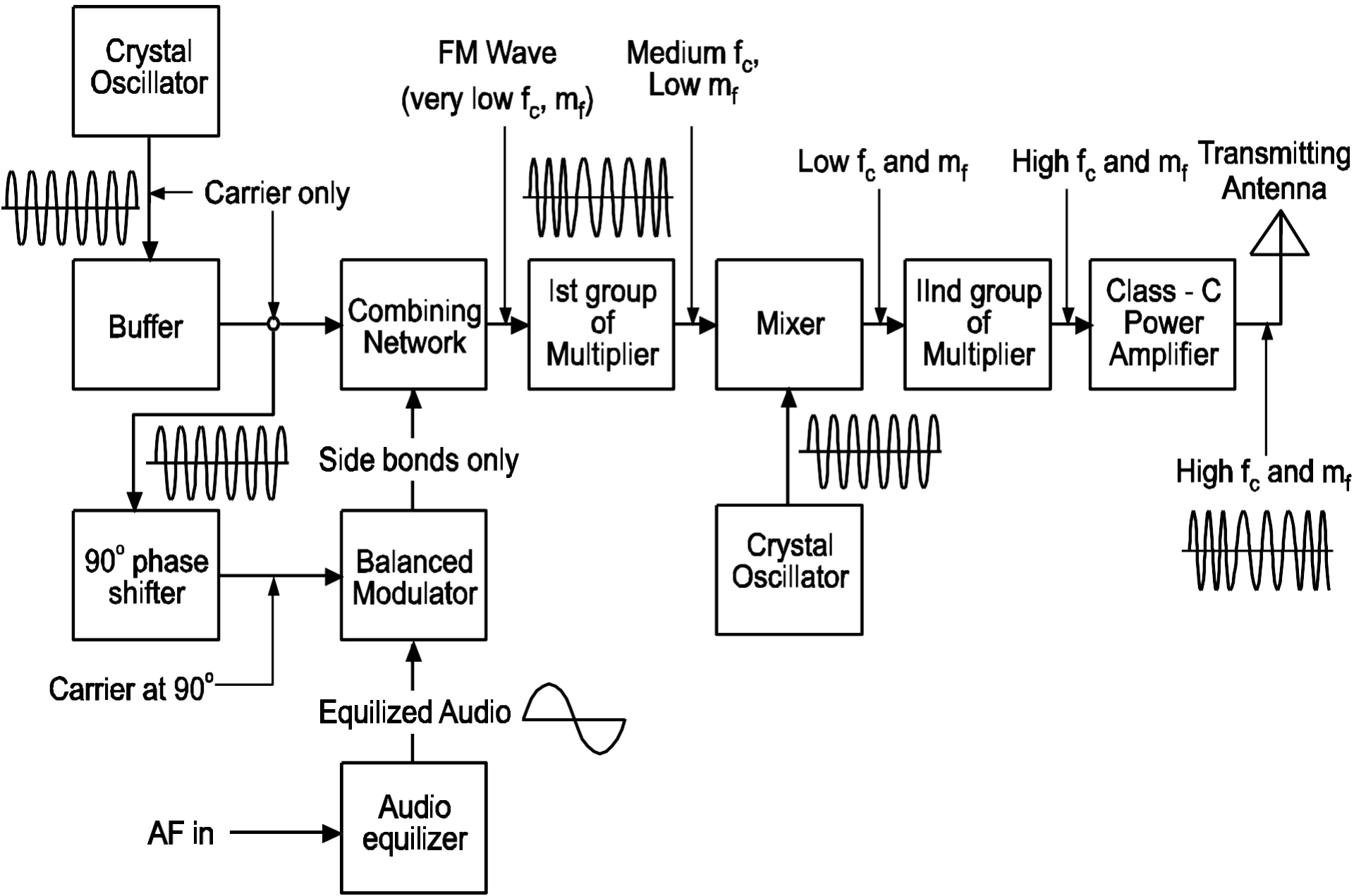

FM Generation using IC 566

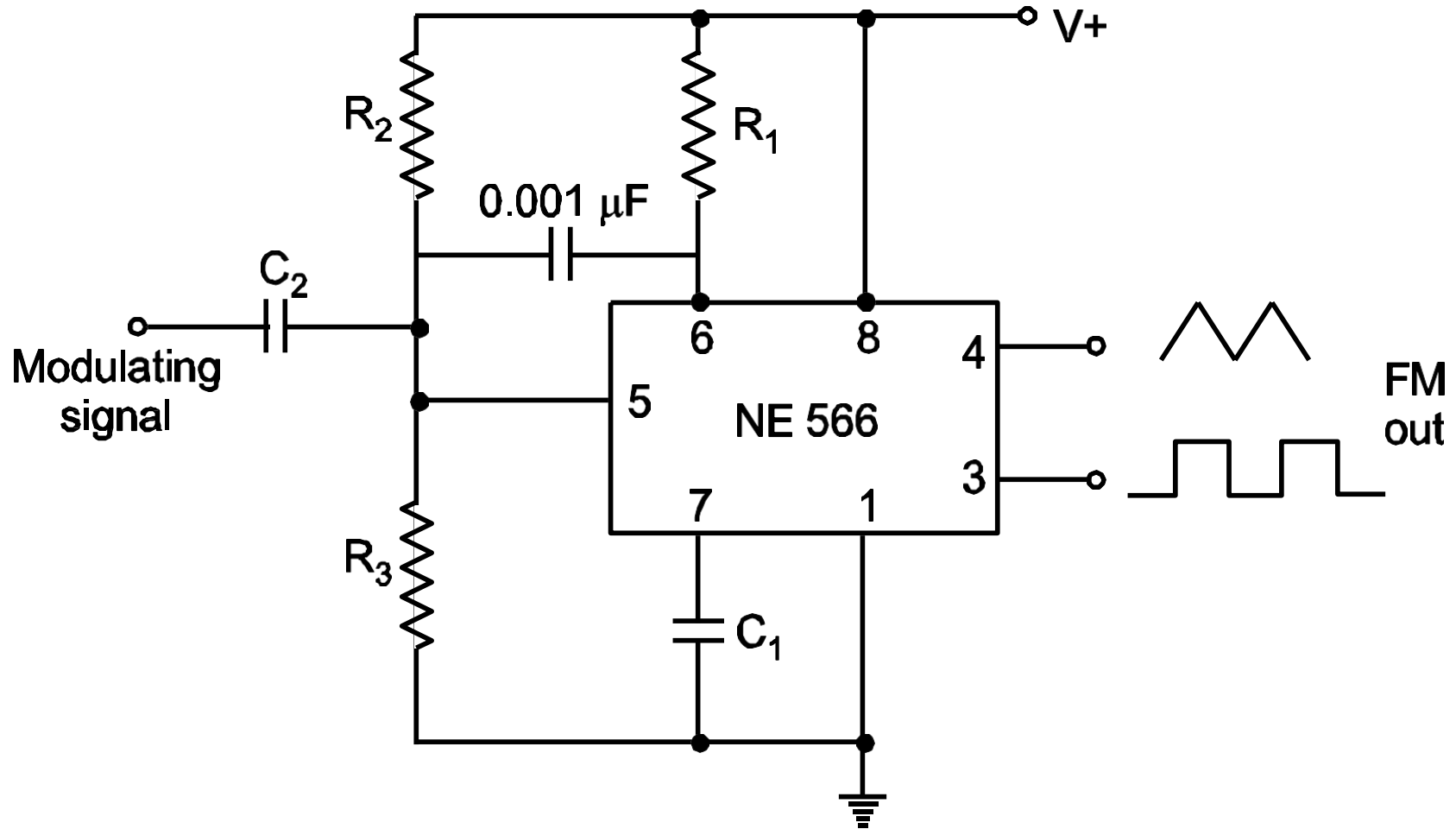

Fig. : Basic Frequency Modulator using NE566 VCO

Advantages/ Disadvantages/Applications of FM

Advantages of FM

1. Transmitted power remains constant.
2. FM receivers are immune to noise.
3. Good capture effect.
4. No mixing of signals.

Disadvantages of FM

The greatest disadvantages of FM are:

1. It uses too much spectrum space.
2. The bandwidth is wider.
3. The modulation index can be kept low to minimize the bandwidth used.
4. But reduction in M.I. reduces the noise immunity.
5. Used only at very high frequencies.

Applications of FM

1. FM radio broadcasting.
2. Sound transmission in TV.
3. Police wireless.

Demodulation of FM Signal

Two steps involved in FM demodulation

- Conversion of FM signal into AM signal, Tank or parallel resonance circuit converts FM into AM signal.
- An envelope detector is used to extract modulating signal from modulated signal.

Slope Demodulator:

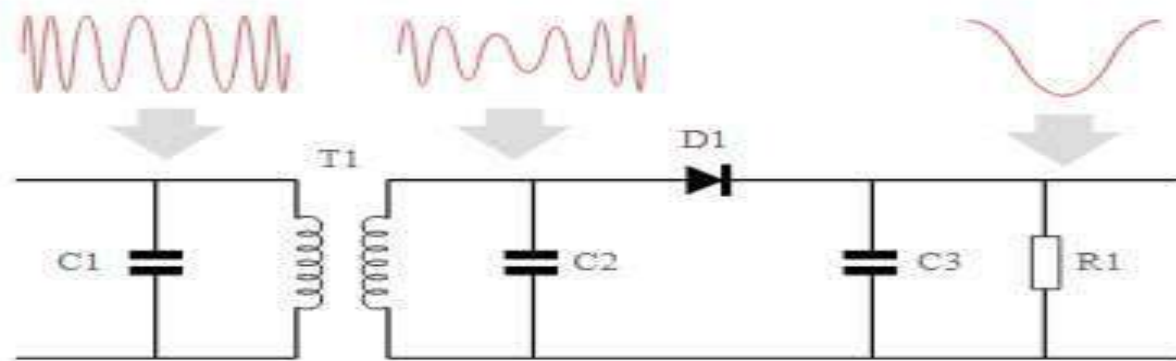

FM slope detector circuit showing the signal waveforms

Demodulation of FM Signal

- The input signal is a frequency modulated signal. It is applied to the tuned transformer (T1, C1, C2 combination) which converts the incoming FM signal into AM.
- This AM signal is applied to a simple diode detector circuit, D1. Here the diode provides the rectification, while C3 removes any unwanted high frequency components, and R1 provides a load.

Advantages:

Simple and low cost

Enables FM to be detected without any additional circuitry.

Disadvantages:

Nonlinear operation

Both frequency and amplitude variations are demodulated and this means that much higher levels of noise and interference are experienced.

Demodulation of FM Signal

Foster Seeley Demodulator or detector:

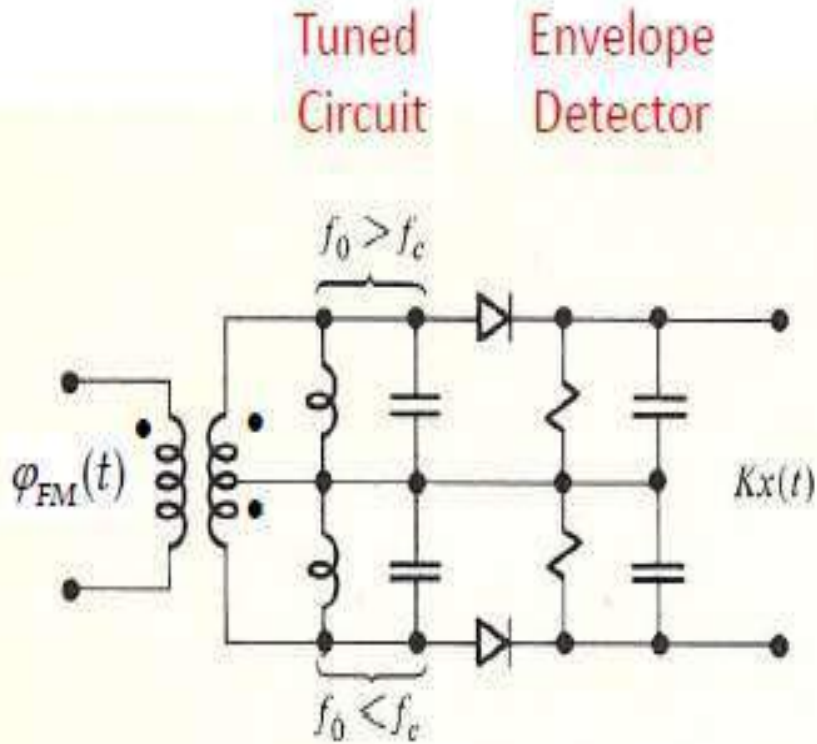

(a)

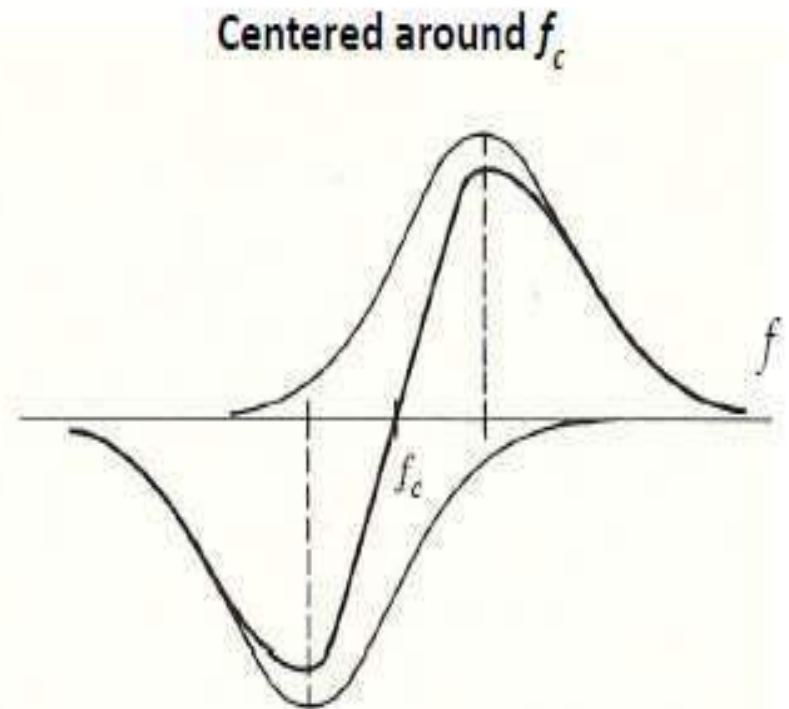

(b)

Transfer Characteristics

Demodulation of FM Signal

- Foster seeley demodulator contains two tuning circuits and two envelope detectors.
- One section of tuning circuit and envelope detector works for incoming frequency is greater than carrier frequency and vice versa for incoming frequency less than carrier frequency.
- Tuning circuit converts FM signal to AM signal and Envelope detector extracts message signal from AM signal.

Demodulation of FM Signal

Ratio Demodulator:

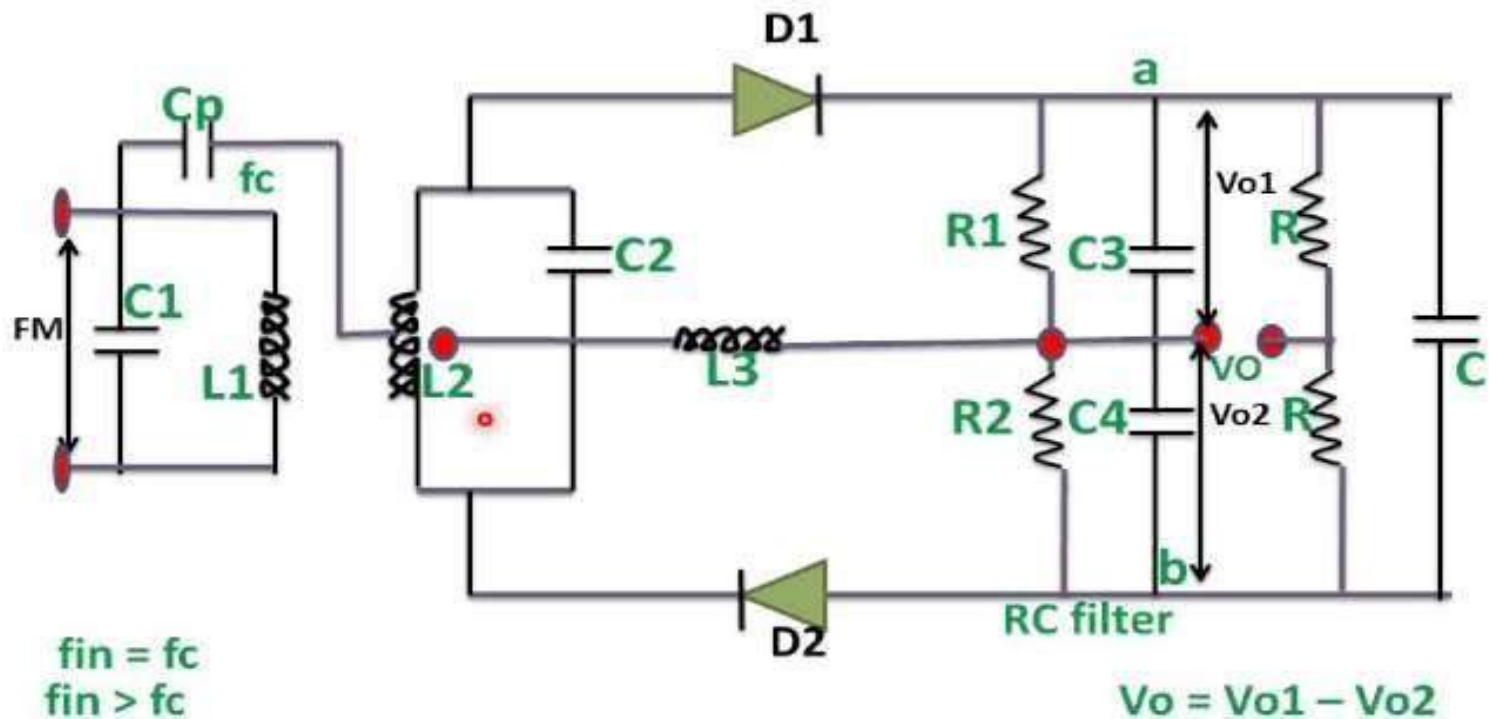

- Ratio detector is similar to Foster seeley demodulator except of Diode of D2 is reversed potential divider circuit.
- Potential divider circuit suppress the noise and this advantage of ratio detector.

Demodulation of FM Signal

PLL Demodulator or detector:

- Phase Locked Loop is closed loop system which contains Phase detector, VCO and loop filter or LPF as shown in figure.

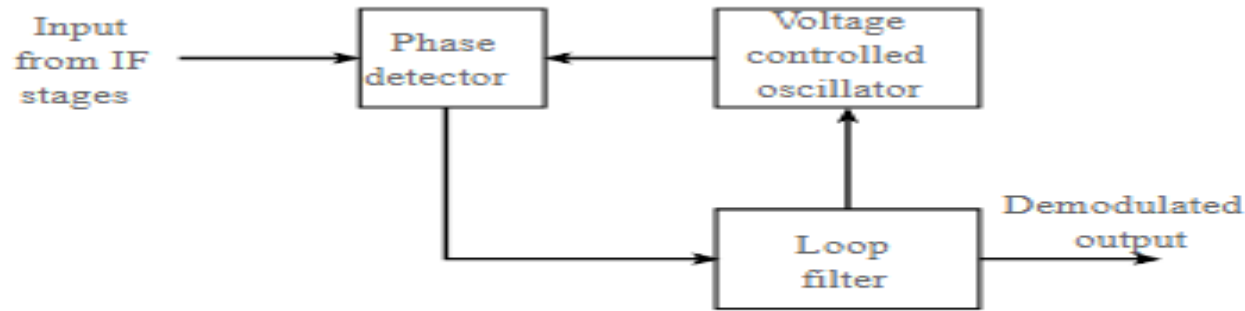

PLL Phase locked Loop FM demodulator

- It continuously finds the phase difference between incoming FM signal and locally generated carrier.
- And based on Phase difference it generates Modulating signal.

Demodulation of FM Signal

Zero Crossing Demodulator or detector:

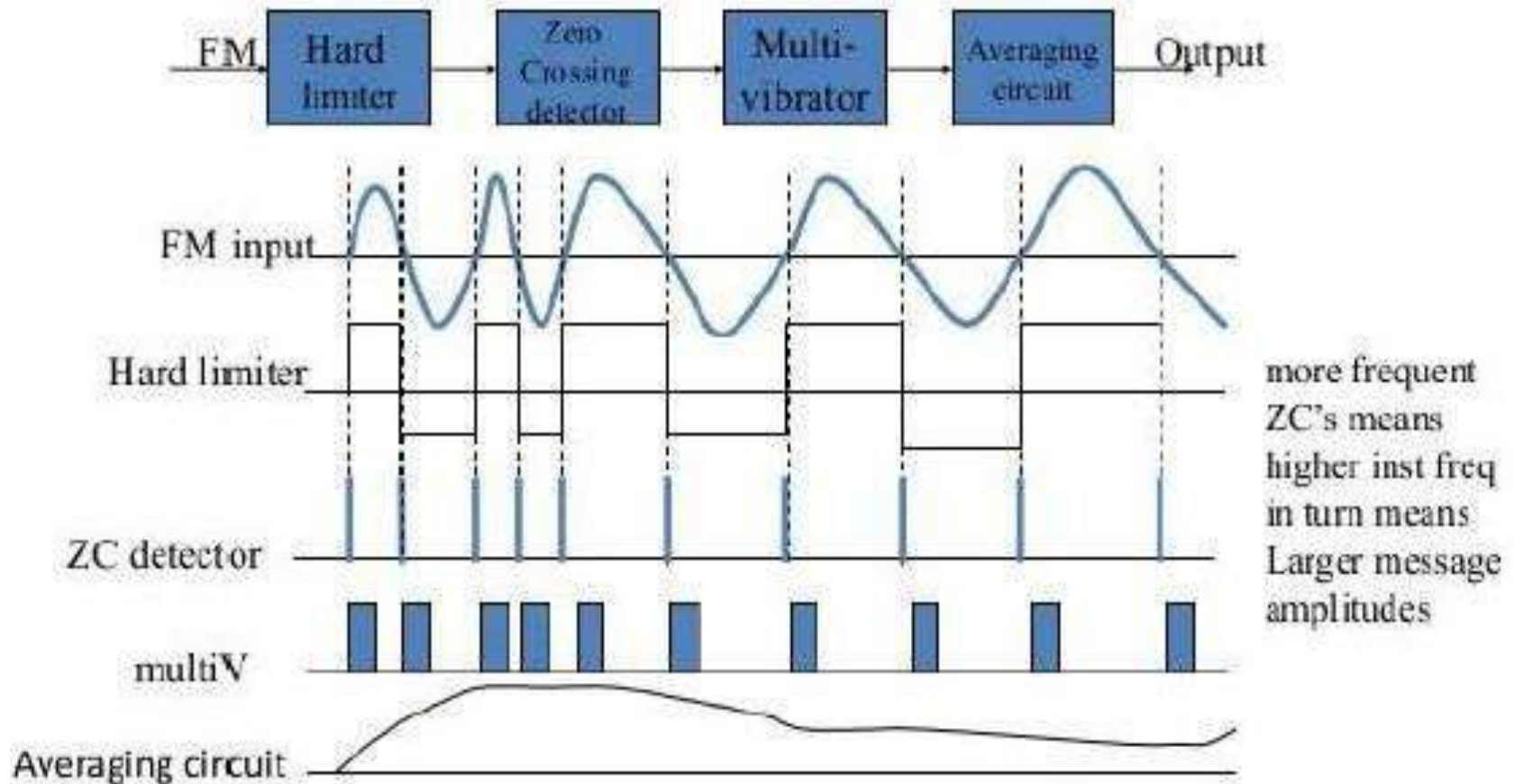

Demodulation of FM Signal

- Zero crossing detector contains hard limiter, Zero crossing detector, Multi vibrator, and Averaging Circuit.
- Hard limiter is two sided independent clipper which converts continuous FM signal into Digital.
- Zero crossing detector is differentiator which generates spikes when signal crosses zero and no. of zero crossings is proportional to modulating signal amplitude.
- Mono stable multivibrator is generates pulses with constant amplitude and width for each spike.
- Averaging is LPF circuit which integrates pulses and generates modulating signal.

Super Heterodyne FM Receiver

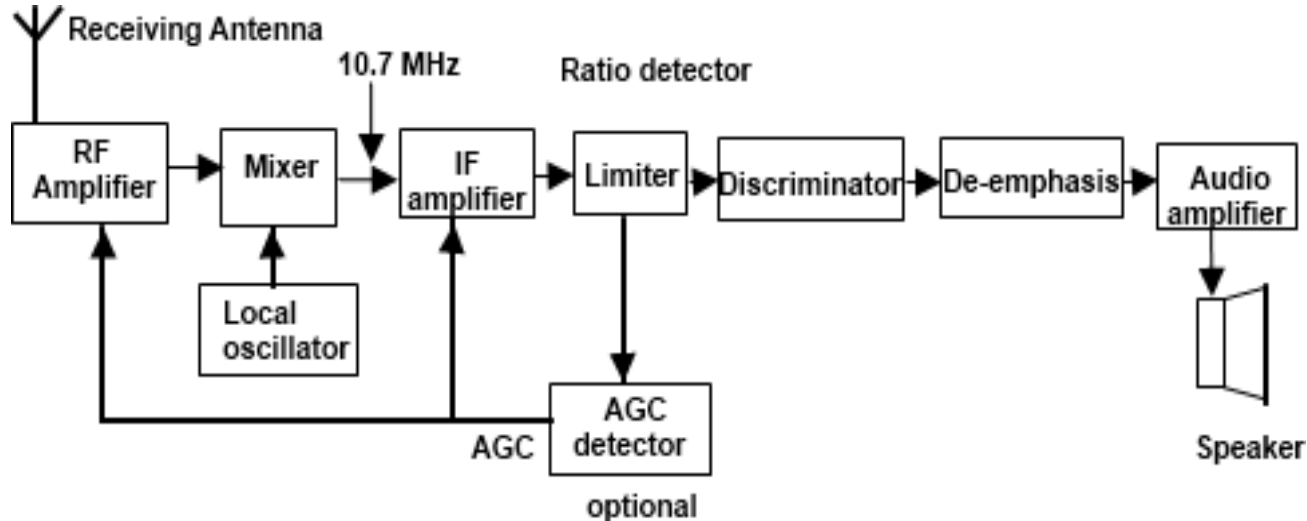

Antenna: It is passive device which converts electromagnetic signal into electrical signal.

RF Tuned Amplifier:

It is broad band amplifier which contain tuning circuit and amplifier.

Tuning circuit designed to select 100 stations and amplifier provides amplification for 20MHz or 20 000 KHz band width.

RF tuned amplifier is responsible for sensitivity, selectivity, Image signal rejection and noise reduction.

Super Heterodyne FM Receiver

Mixer: It is combination of frequency mixer and Band Pass Filter (BPF).

Frequency generates sum and difference frequency of incoming signal and locally generated signal.

BPF selects difference frequency at the output whose center frequency is equal to $= 10.7\text{MHz}$.

Local Oscillator:

It is either Colpits or Hartley oscillator.

It generates carrier frequency 10.7MHz . greater than the incoming carrier frequency to produce constant or fixed frequency.

IF Amplifier:

It is narrow band, high gain and fixed frequency amplifier which provides amplification for 20 MHz band width at center frequency of 10.7 MHz .

Super Heterodyne FM Receiver

Limiter:

It is combination of hard limiter and BPF.

Hard limiter is two sided independent clipper removes the noise spikes.

Detector or Demodulator or Discriminator:

It is frequency translator circuit which extracts modulating signal from FM signal.

De-emphasis:

It is LPF which attenuates frequencies of Audio signal from 2 KHz to 20 KHz to get the original modulating signal.

Audio Amplifier:

It is low frequency amplifier which provides amplification at (20-20K) Hz.

Loud Speaker:

It converts Electrical signal into sound or audio signal.

Frequency Division Multiplexing

Allocation of different frequency bands or carrier frequency to different channel is called “Frequency Division Multiplexing”. And it is used to transmit Radio & TV signals.

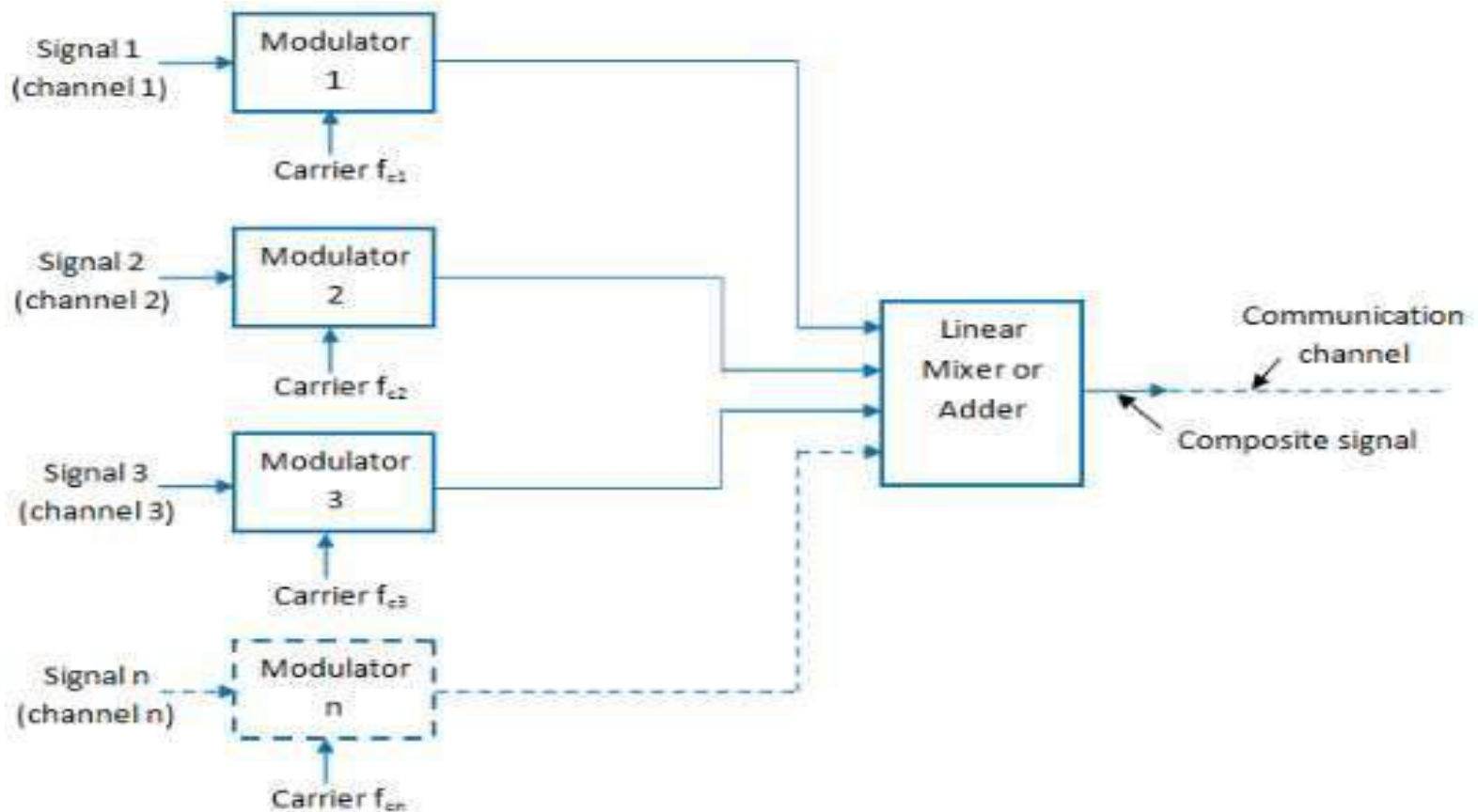

Frequency Division Multiplexing

FDM Multiplexing:

- Different carrier frequencies are used for different stations or channels.
- Modulator is used in the transmitter

Band width of FDM system,

$$BW_{FDM} = N \cdot BW_{CH} + (N-1) BW_G$$

Where,

N = No. of channels or stations

BW_{CH} = Bandwidth of each channel

BW_G = Bandwidth of guard band

Guard band is frequency gap between two channels

Frequency Division Multiplexing

FDM De-Multiplexing:

- BPF filter is used select channels or stations
- Demodulator is used in the receiver.

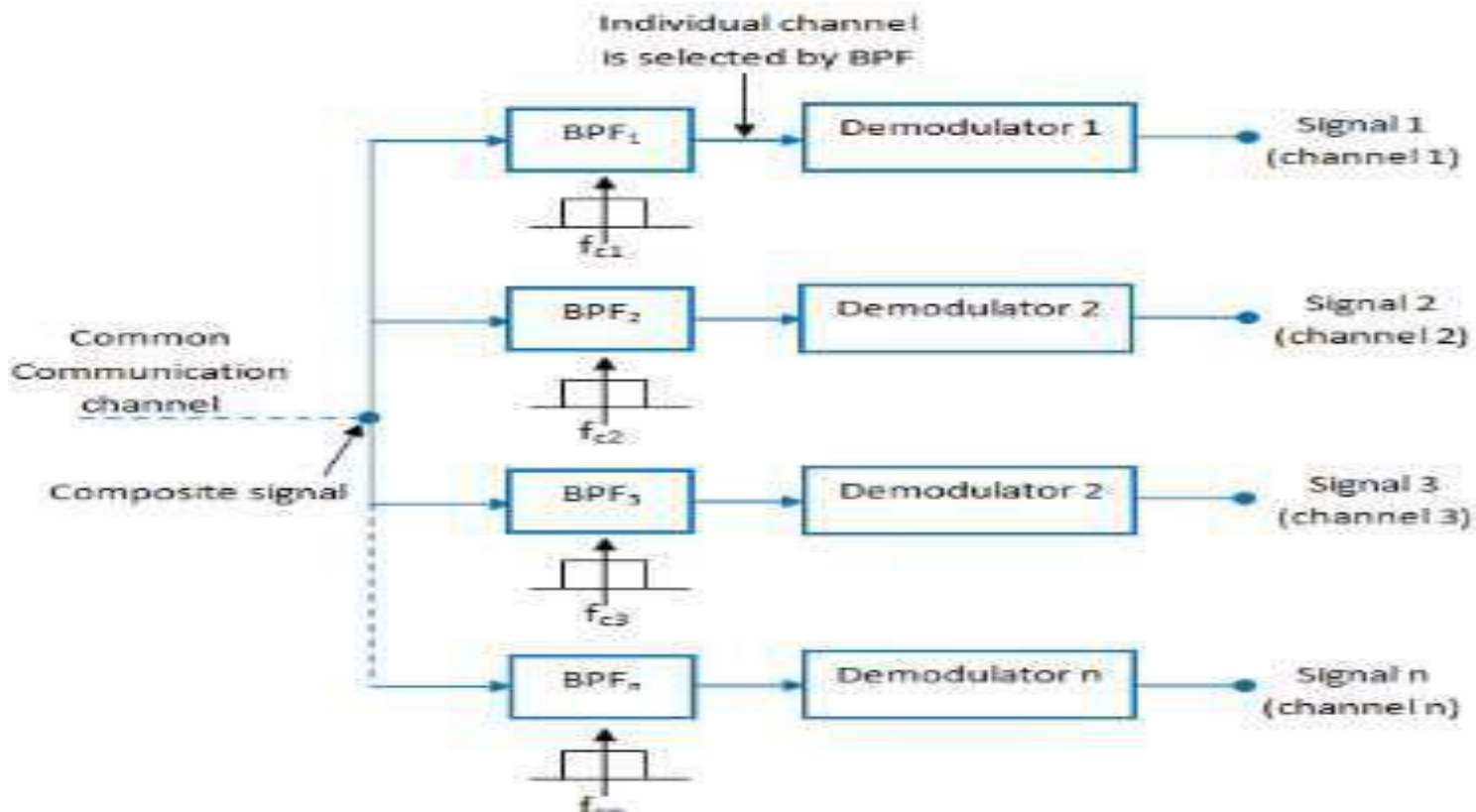

NOISE IN COMMUNICATION SYSTEMS

Noise: It is an unwanted signal which tends to interfere with the modulating signal.

Types of noise:

Noise is basically divided into,

1. External Noise
2. Internal Noise

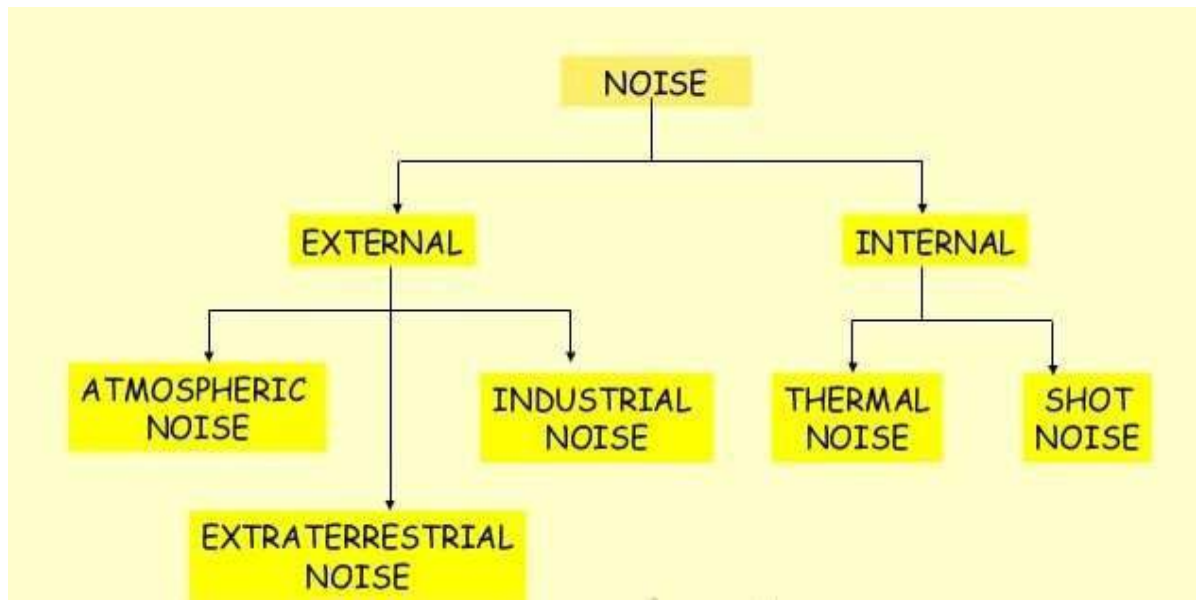

Classification of Noise

1. External Noise:

- **Atmospheric Noise:** Radio noise caused by natural atmospheric processes, primarily lightening discharges in thunder storms.
- **Extraterrestrial Noise:** Radio disturbances from sources other than those related to the Earth.
 - Cosmic Noise:** Random noise that originates outside the Earth's atmosphere.
 - Solar Noise:** Noise that originates from the Sun is called Solar noise.

Classification of

Noise

- **Industrial Noise:** Noise generated by automobile ignition, aircrafts, electric motors, Switch gears, welding etc.

2. Internal Noise:

- **Shot Noise:** Random motion of electrons in the semiconductor devices generates shot noise.
- **Thermal or Johnson's Noise:** Random motion of electrons in the resistor is called Thermal noise.

$$V_n = \sqrt{4kTB R}$$

Where, k = Boltzmann constant, R = Resistance

T_0 = Absolute temperature B = Bandwidth

Noise Temperature and Noise

Noise temperature(T_e): It is a means for specifying noise in terms of an equivalent temperature. It is expressed as ,

$$T_e = (F_n - 1) T_0$$

Where, F_n = Noise Figure, T_0 = Absolute temperature

Noise figure(F_n): It is the ratio of output and input noise of an amplifier or network. It is expressed as,

$$F_n = \frac{KT_0BG + \Delta N}{KT_0BG}$$

Where, Δ = Noise added by the network or amplifier.

G = gain of an network or amplifier

Noise Temperature and Noise Figure

Noise Figure of Cascade Amplifier or Network:

Noise Figure of an cascade network or amplifier is expressed as,

$$F_n = F_1 + \frac{(F_2 - 1)}{G_1} + \frac{F_3 - 1}{G_1 G_2} + \frac{F_4 - 1}{G_1 G_2 G_3} + \dots + \frac{F_n - 1}{[G_1 G_2 G_3 \dots G(n-1)]}$$

Where, F_1 = Noise figure of 1st stage

G_1 = Gain of 1st stage

F_2 = Noise figure of 2nd stage

G_2 = Gain of 2nd stage

F_n = Noise figure of nth stage

G_n = Gain of nth stage

Noise equivalent

Bandwidth

When white noise (flat spectrum of frequencies like white light) is passed through a filter having a frequency response, some of the noise power is rejected by the filter and some is passed through to the output.

The noise equivalent bandwidth is defined in the following picture,

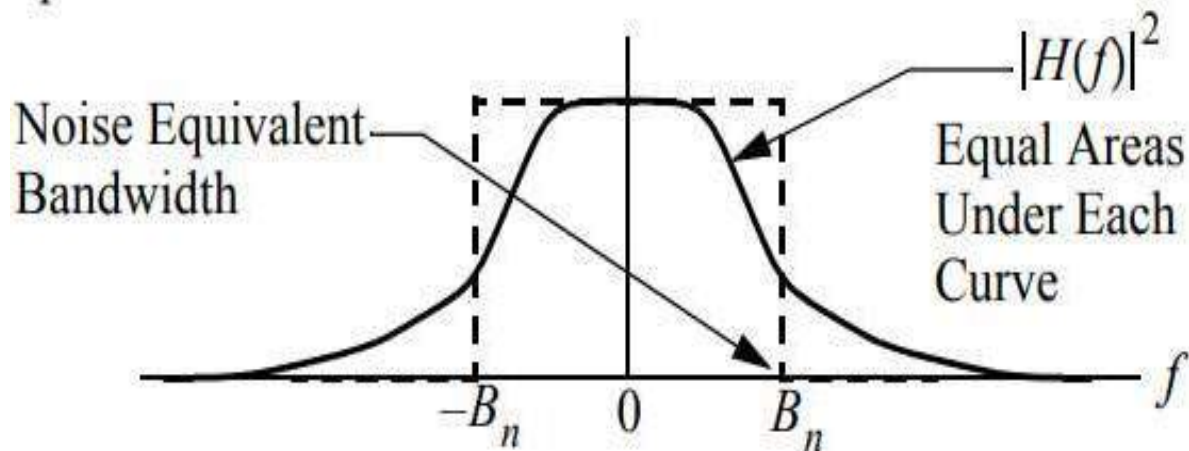

Figure 01

Merit

Figure of Merit (FOM): It is ratio of output SNR to input SNR of a communication system.

$$\text{FOM} = \frac{S_o/N_o}{S_i/N_i}$$

Where S_o = Output Signal Power & N_o = Output Noise Power

S_i = Input Signal Power & N_i = Input Noise Power

Receiver model for noise calculation:

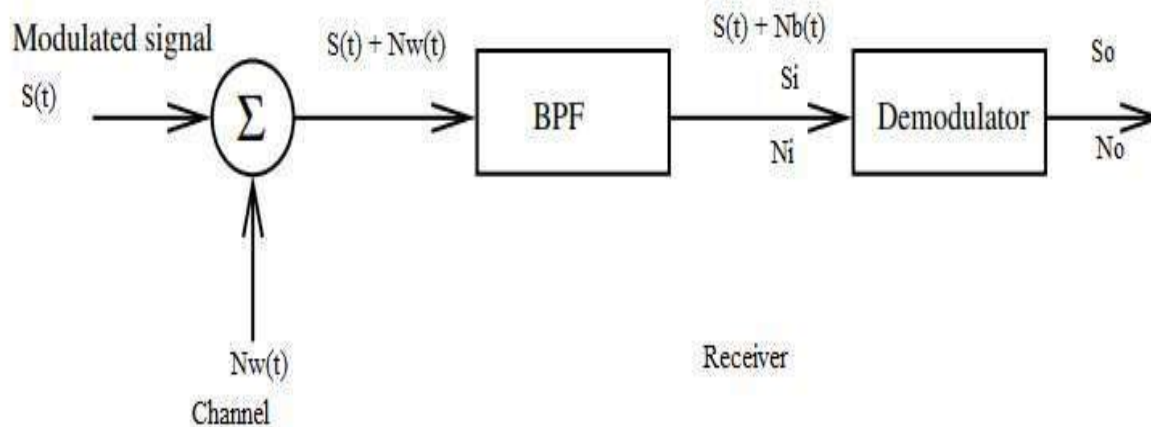

Receiver model for noise

calculation

- The receiver is combination of Band Pass Filter (BPF) and Demodulator.
- The BPF is combination of RF Tuned Amplifier, Mixer and Local Oscillator whose band width is equal to band width of modulated signal at transmitter.
- Channel Inter connects transmitter & receiver. Channel adds noise to the modulated signal while transmitting and it is assumed to be white noise whose Power Spectral Density is uniform.
- BPF converts white noise in to color or Band pass noise or narrow band pass noise.

Receiver model for noise calculation

PSD of white noise and Narrow band pass noise are,

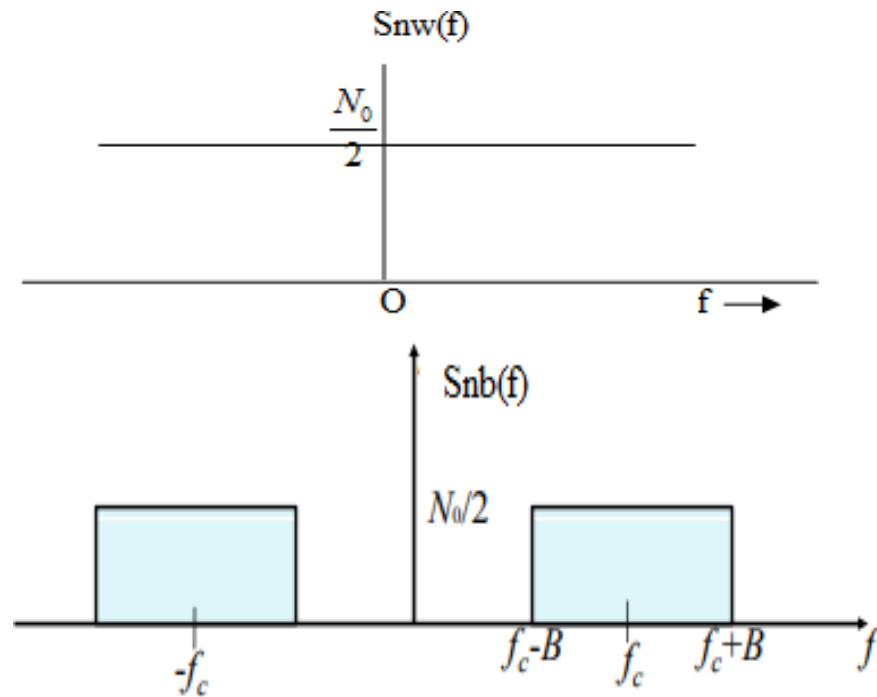

$$\text{Power of band pass noise } P = \int_{f_c - B}^{f_c + B} \frac{N_0}{2} df = N_0 B$$

Where B = Band width noise.

Communication system model for

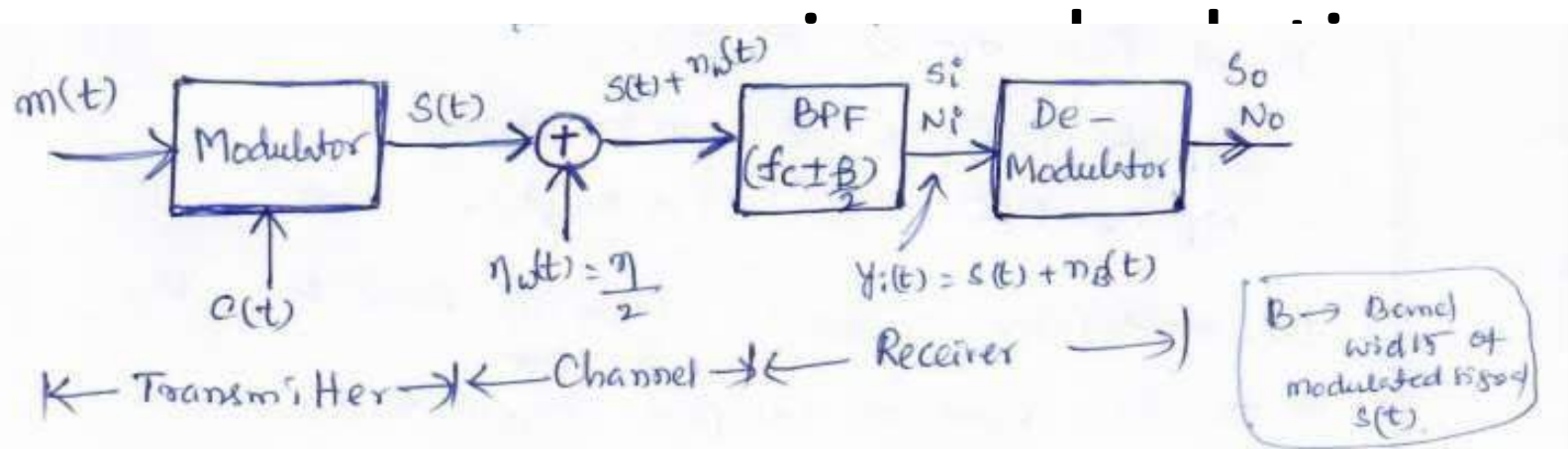

- The communication system model for noise calculation contains transmitter, channel and receiver.
- Transmitter is replaced by modulator which converts low frequency modulating signal $x(t)$ into high frequency bandpass signal with the help of carrier signal.
- Channel is replaced or modelled as additive noise which adds white noise with PSD $\eta/2$ and it contains all frequencies.

Communication system model for

noise calculation

- Receiver is modelled as BPF followed by demodulator.
- BPF is combination of RF tuned amplifier, mixer , local oscillator.
- Passband or badnwidth of BPF is equal to bandwidth of modulated signal.
- BPF converts white noise into color or bandpass noise $\eta_B(t)$.

Input to BPF is $s(t) + \eta_w(t)$

Output of BPF is $s(t) + \eta_B(t)$

- Demodulator converts high frequency or bandpass signal into low frequency or baseband signal.

Bandpass noise

representation

Bandpass noise is represented by,

1. Time Domain representation

- Quadrature representation
- Envelope representation

2. Frequency Domain representation

Quadrature representation:

Bandpass noise can be represented as,

$$\eta_B(t) = \eta_i(t) \cos W_c t + \eta_q(t) \sin W_c t$$

Where, $\eta_B(t)$ = Bandpass noise

$\eta_i(t)$ = Inphase component of lowpass noise

$\eta_q(t)$ = Quadrature component of lowpass noise

Quadrature representation

$\eta_i(t)$ and $\eta_q(t)$ can be recovered from $\eta_B(t)$,

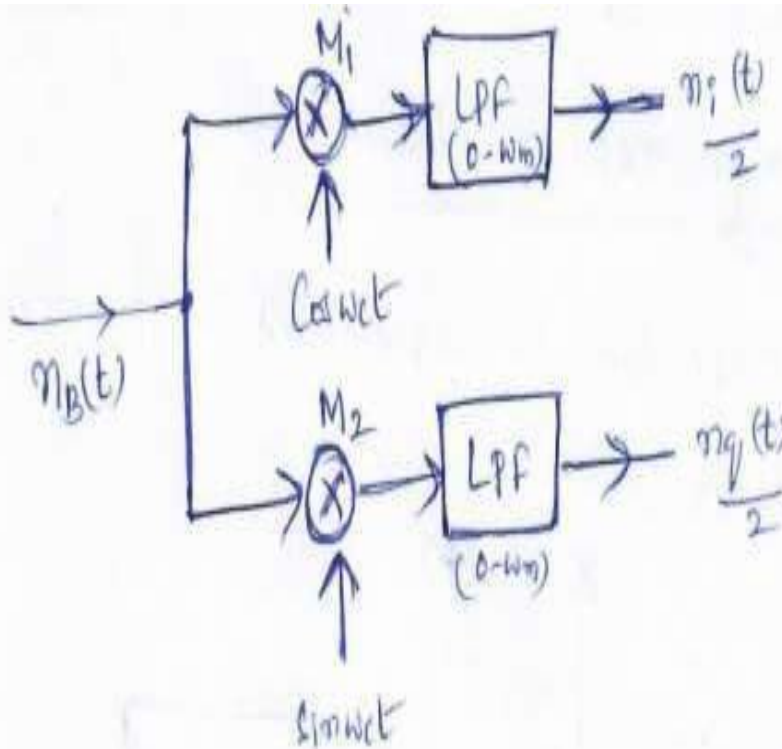

Bandpass noise

Frequency domain representation:

Bandpass noise can be represented in frequency domain

as,

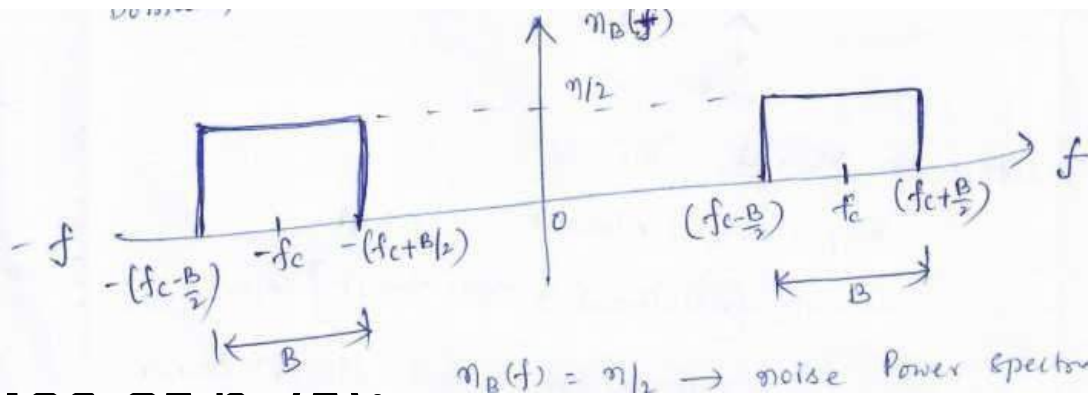

Properties of $\eta_B(t)$:

- $\eta_B(t)$, $\eta_i(t)$, $\eta_q(t)$ will have same power.
- The PSD of $\eta_i(t)$ & $\eta_q(t)$ is,

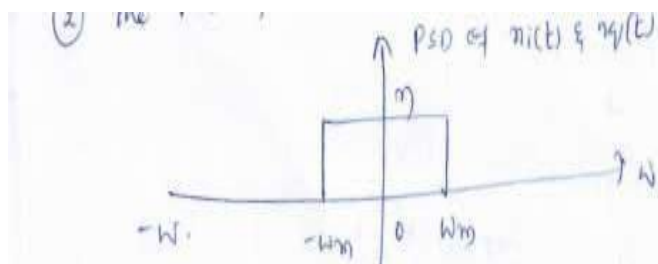
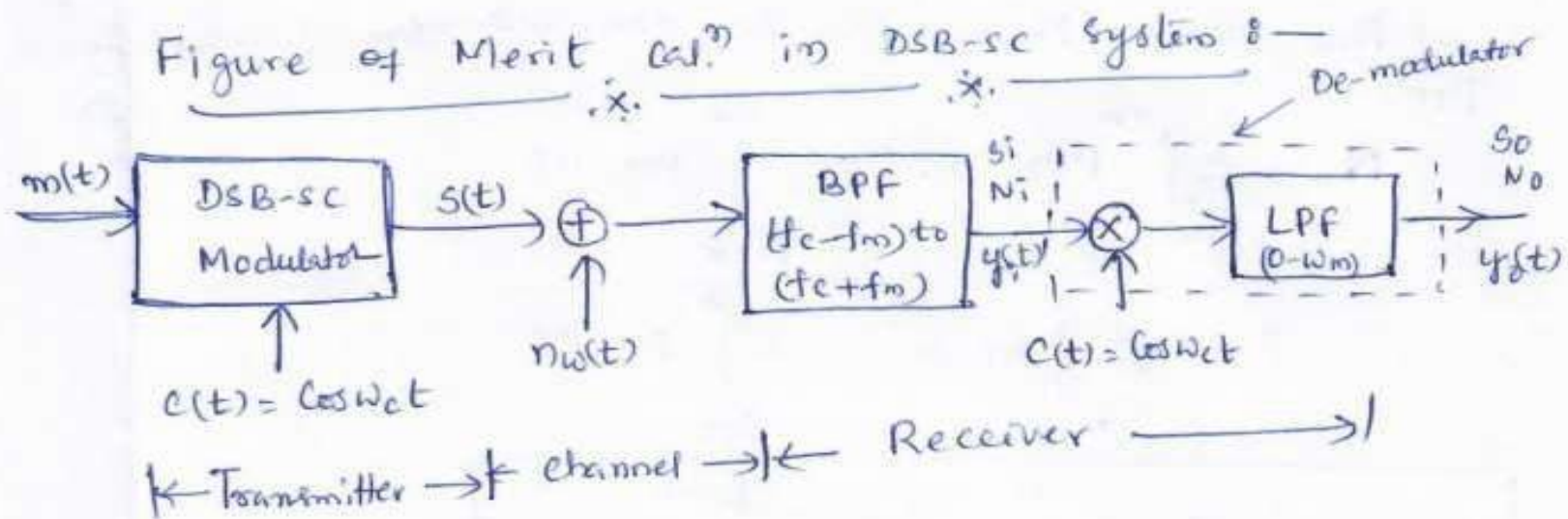

Figure of Merit calculation in DSB-SC



- Transmitter contains DSB-SC modulator, whose output $s(t) = m(t) \cos \omega_c t$.
- Noise generated by the channel is considered as white noise $\eta_w(t)$ with uniform noise power spectral density $\eta/2$.

Figure of Merit calculation in

DSB-SC

- Band pass filter's bandwidth is equal to modulated signal bandwidth.
- BPF allows DSB-SC signal and converts white noise into color noise or bandpass noise $\eta_B(t)$.

Therefore, o/p of the BPF is $y_i(t) = s(t) + \eta_B(t)$.

- Synchronous detector is used to extract modulating signal $m(t)$ which contain multiplier followed by low pass filter.

Input signal power is , $S_i = m^2(t)/2$, Input noise power, $N_i = \eta \cdot 2f_m$,
Output signal power, $S_0 = [m(t)/2]^2$, Output noise power, $N_0 = \eta \cdot f_m/2$

Substituting these values, $FOM = (S_0/N_0)/(S_i/N_i) = 2$

Figure of Merit calculation in

SSB-SC

SSB-SC signal, $s(t) = m(t)\cos\omega_c t \pm mh(t)\sin\omega_c t$

Output of BPF, $y_i(t) = s(t) + \eta_B(t)$

Bandpass noise, $\eta_B(t) = \eta_i(t) \cos W_c t \pm \eta_q(t) \sin W_c t$

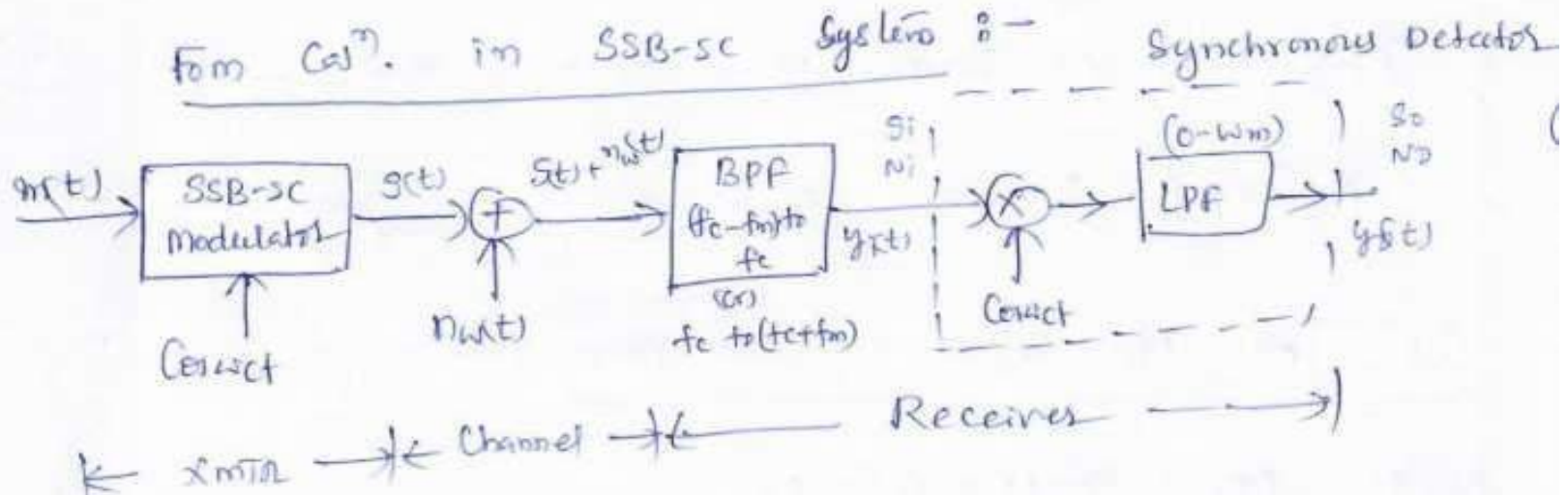

Input signal power is , $S_i = m^2(t)$, Input noise power, $N_i = \eta \cdot f_m$

Output signal power, $S_o = m^2(t)/4$, Output noise power, $N_o = \eta \cdot f_m/4$

Substituting these values, $FOM = (S_o/N_o)/(S_i/N_i) = 1$

Noise calculation in AM

system

AM signal, $S(t) = [A_c + m(t)] \cos \omega_c t$

Output of BPF is, $y_i(t) = s(t) + \eta_B(t)$

$= [A_c + m(t)] \cos \omega_c t + \eta_B(t)$

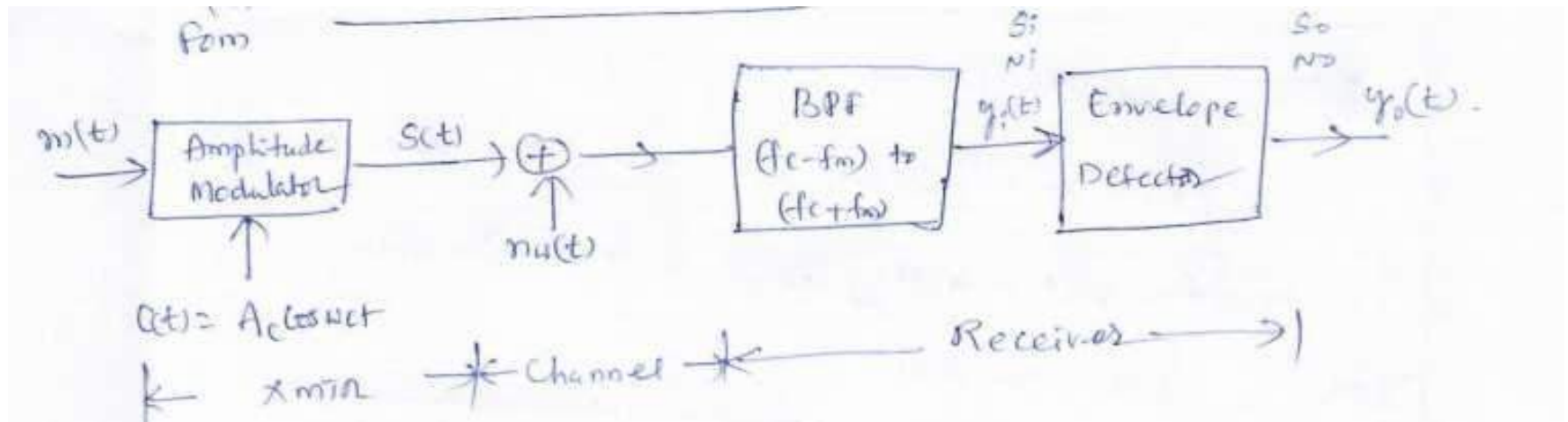

Input signal power is , $S_i = [A_c^2/2] + [m^2(t)/2]$

Input noise power, $N_i = 2 \eta \cdot F_m$, Output signal power, $S_0 = m^2(t)$

Output noise power, $N_0 = 2\eta \cdot F_m$

Using these values, $FOM = 2$.

Noise calculation in FM

system

Frequency modulated signal $s(t) = A_c \cos [\omega_c t + K_f \int m(t) dt]$

Output of BPF is, $y_i(t) = s(t) + \eta_B(t)$

$$= A_c \cos [\omega_c t + K_f \int m(t) dt] + \eta_B(t)$$

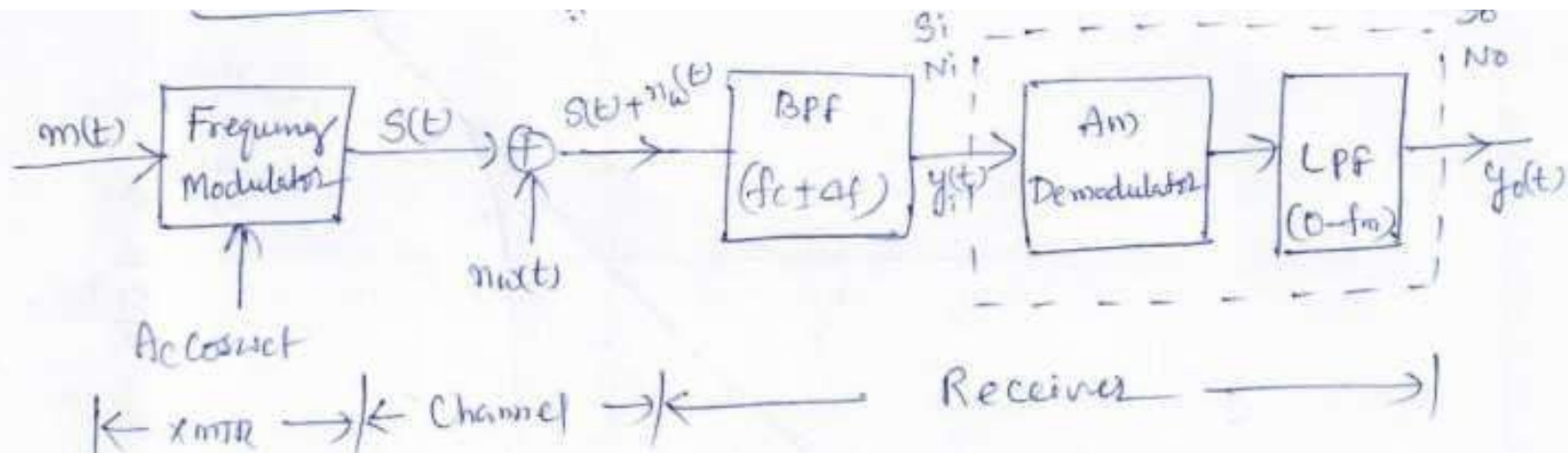

Input signal power is , $S_i = A_c^2/2$, Input noise power, $N_i = 2 \eta \cdot \Delta f$

Output signal power, $S_o = \gamma^2 K_f^2 m^2(t)$

Substituting these values, $FOM = (S_o/N_o)/(S_i/N_i)$

$$FOM = (3/4\pi^2) m_f^3, \quad \text{Where } m_f = \Delta f / f_m$$

Noise calculation in PM

PM signal $S(t) = A_c \cos[\omega_c t + K_p m(t)]$

Output of BPF is, $y_i(t) = s(t) + \eta_B(t)$

$$= A_c \cos[\omega_c t + K_p m(t)] + \eta_B(t)$$

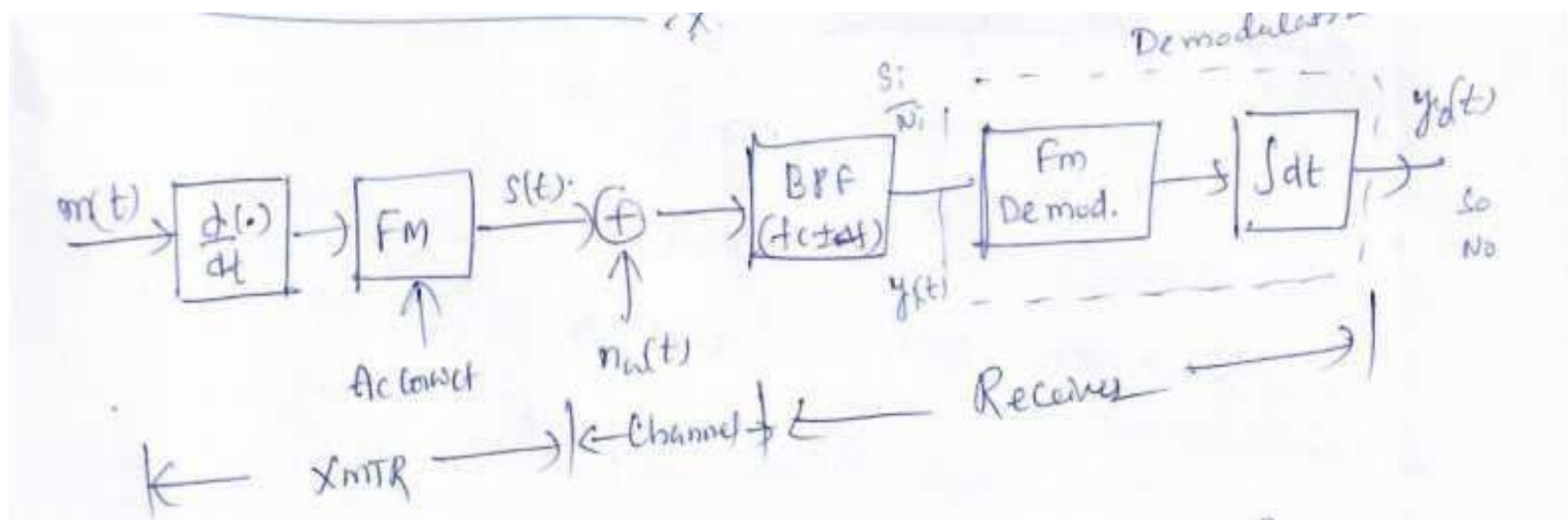

Input signal power is , $S_i = A_c^2/2$, Input noise power, $N_i = 2 \eta \cdot \Delta f$

Output signal power, $S_o = \gamma^2 K_p^2 m^2(t)$, Output noise power, $N_o = 2 \eta$.

Fm

Substituting these values and substituting $m^2(t) = A_m^2/2$

$$FOM = (S_o/N_o)/(S_i/N_i) = m_p^2 (\Delta f / f_m)$$

Comparison between different Modulation Systems

<u>S.No.</u>	Modulation System	FOM
1.	DSB-SC	2
2.	SSB-SC	1
3.	AM with Envelope Detector	$2 \frac{\overline{m^2(t)}}{A_c^2 + \overline{m^2(t)}}$
4.	AM with Square Law Detector	$2 \frac{\overline{m^2(t)}}{A_c^2 + \overline{m^2(t)}} \times \frac{1}{1 + \frac{\overline{m^2(t)}}{A_c^2}}$
5.	FM	$\frac{3}{4\pi^2} m_f^3$
6.	PM	$m_p^2 \frac{\Delta f}{f_m}$

ANALOG PULSE MODULATION SCHEMES

Pulse Modulation:

The process of transmitting the signals in the form of pulses by using some special techniques.

There are two types of pulse modulation systems,

1. Pulse Amplitude Modulation
2. Pulse Time Modulation

Pulse time modulation is further divided into,

- Pulse Width Modulation
- Pulse Position Modulation

PULSE AMPLITUDE MODULATION(PAM)

In Pulse amplitude modulation, the amplitude of pulses of carrier pulse train is varied in accordance with the modulating signal.

In PAM , the pulses can be flat top type or natural type or ideal type.

Out of these, flat top PAM is widely used because of easy noise removal.

PAM

GENERATION

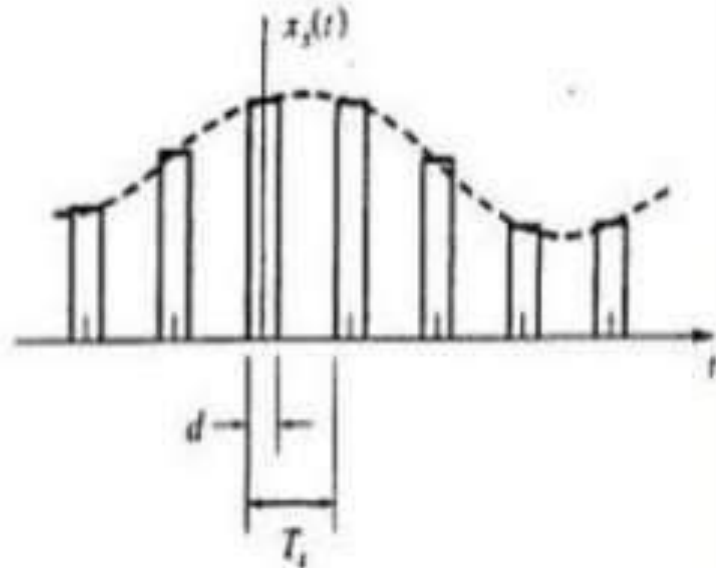
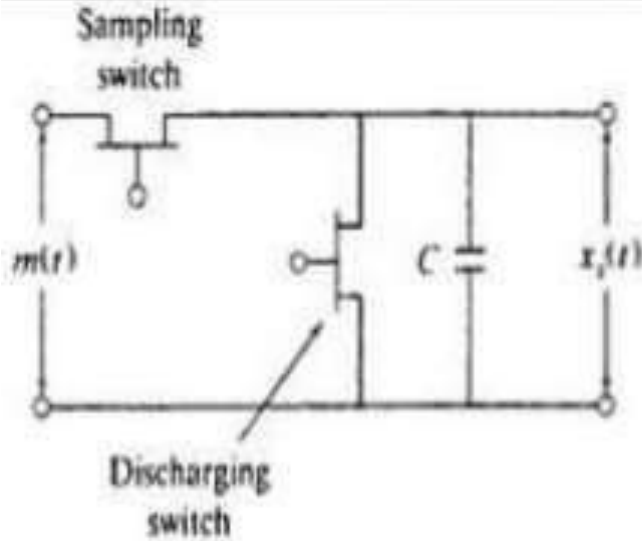

- The sample and hold circuit consists of two FETs and a capacitor.
- The sampling switch is closed for a short duration by a short pulse applied to the gate G1 of transistor.

PAIVI

GENERATION

- During this period, the capacitor is quickly charged to a voltage equal to instantaneous sample value of incoming signal $x(t)$
- Now the sampling switch is opened and capacitor holds the charge.
- The discharge switch is then closed by a pulse applied to gate G2 of second transistor.
- Due to this the capacitor is discharged to zero volts. The discharge switch is then opened and the capacitor has no voltage.
- Hence the output of sample and hold circuit consists of a sequence of flat top samples.

PAM GENERATION

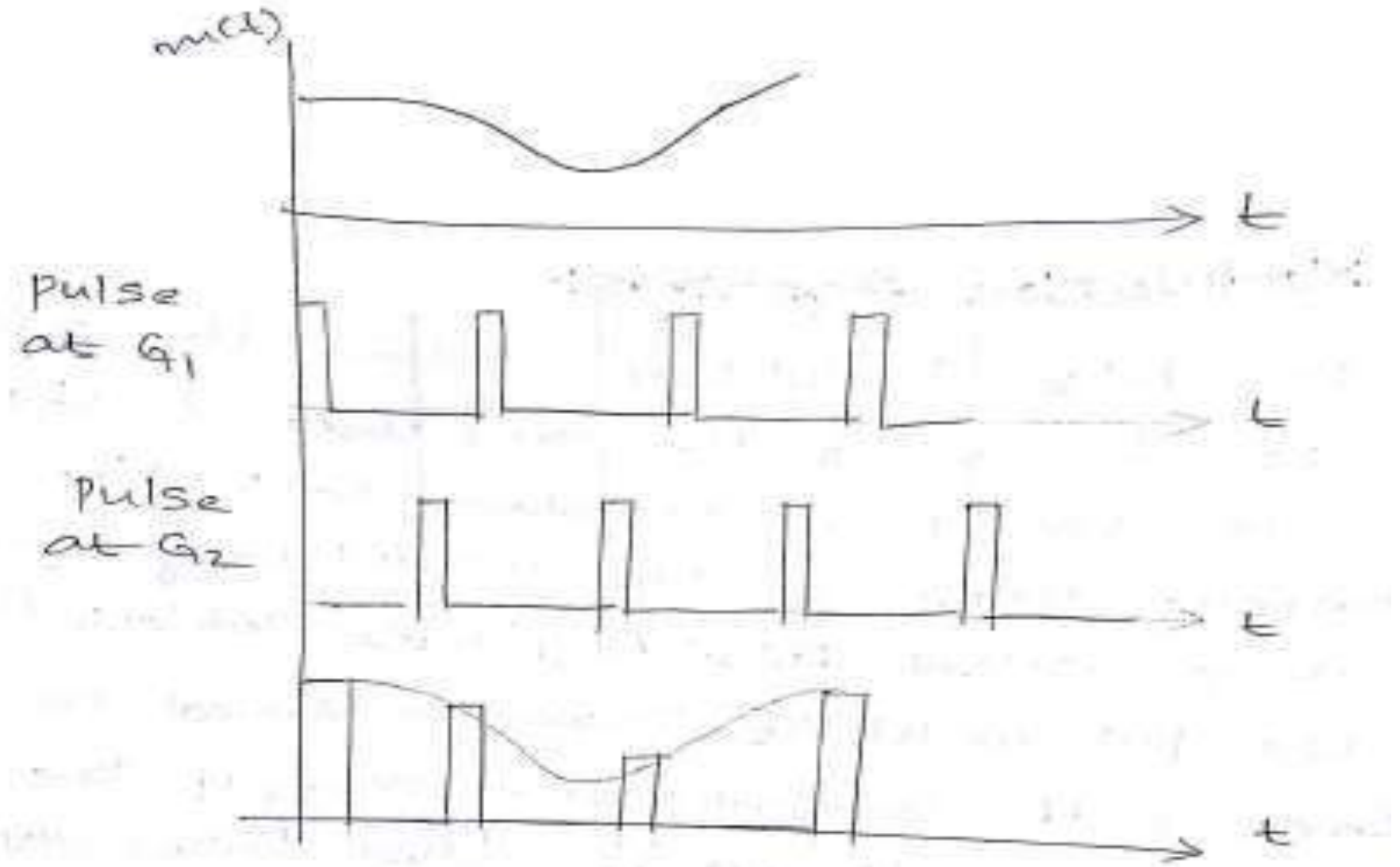

Transmission bandwidth of

PAM

In PAM signal the pulse duration τ is assumed to be very small compared to time period T_s i.e $\tau < T_s$

If the maximum frequency in the modulating signal $x(t)$ is f_m then sampling frequency f_s is given by $f_s \leq 2f_m$ Or $1/T_s \leq 2f_m$ or $T_s \leq 1/2f_m$

Therefore, $\tau < T_s \leq 1/2f_m$

If ON and OFF time of PAM pulse is equal then maximum frequency of PAM pulse will be $f_{max} = 1/(\tau + \tau) = 1/2\tau$

Therefore, transmission bandwidth $\geq 1/2\tau \geq 1/[2(1/2f_m)] \geq f_m$

Demodulation of

Demodulation is the reverse process of modulation in which modulating signal is recovered back from the modulated signal.

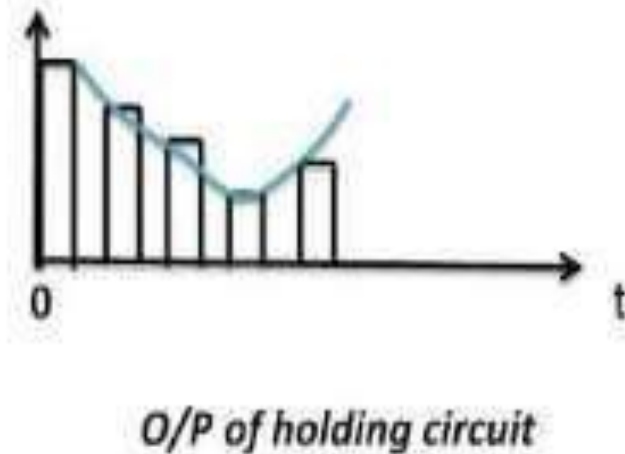
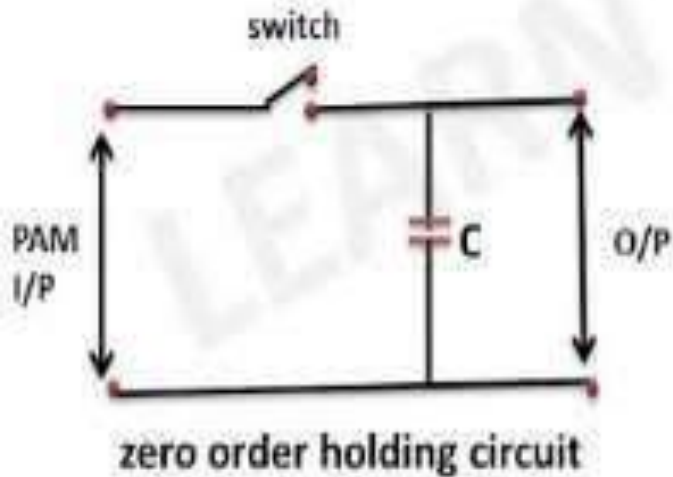

Demodulation of

PAM

- For PAM signals, demodulation is done using a holding circuit.
- The received PAM signal is first passed through a holding circuit and then through a lowpass filter.
- Switch S is closed during the arrival of the pulse and is opened at the end of the pulse.
- Capacitor C is charged to pulse amplitude value and holds this value during the interval between two pulses.
- Holding circuit output is then passed through a low pass filter to extract the original signal.

Advantages, Disadvantages

Advantages: of PAM

- It is the simple process for modulation and demodulation
- Transmitter and receiver circuits are simple and easy to construct.

Disadvantages:

- Bandwidth requirement is high
- Interference of noise is maximum
- Power requirement is high

Applications:

- Used in microcontrollers for generating control signals
- Used as electronic driver for LED lighting

SAMPLI

NG

It is the process of converting a continuous time signal into a discrete time signal

During sampling, sufficient number of samples of the signal must be taken so that original signal is correctly represented in its samples and possible for reconstruction.

Number of samples to be taken depends on maximum signal frequency present in the signal.

- Different types of samples are,
- Ideal
- Natural
- Flat top

SAMPLI

NG

Sampling theorem:

A continuous time signal may be completely represented in its samples and recovered back if the sampling frequency $f_s > 2f_m$

Nyquist rate and Nyquist interval:

When sampling rate becomes exactly equal to $2f_m$ samples per second, it is called Nyquist rate

$$f_s = 2f_m \text{ Hz}$$

Maximum sampling interval is called Nyquist interval.

$$T_s = 1/f_s = 1/2f_m \text{ sec}$$

NATURAL SAMPLING

In natural sampling, pulse has a finite width

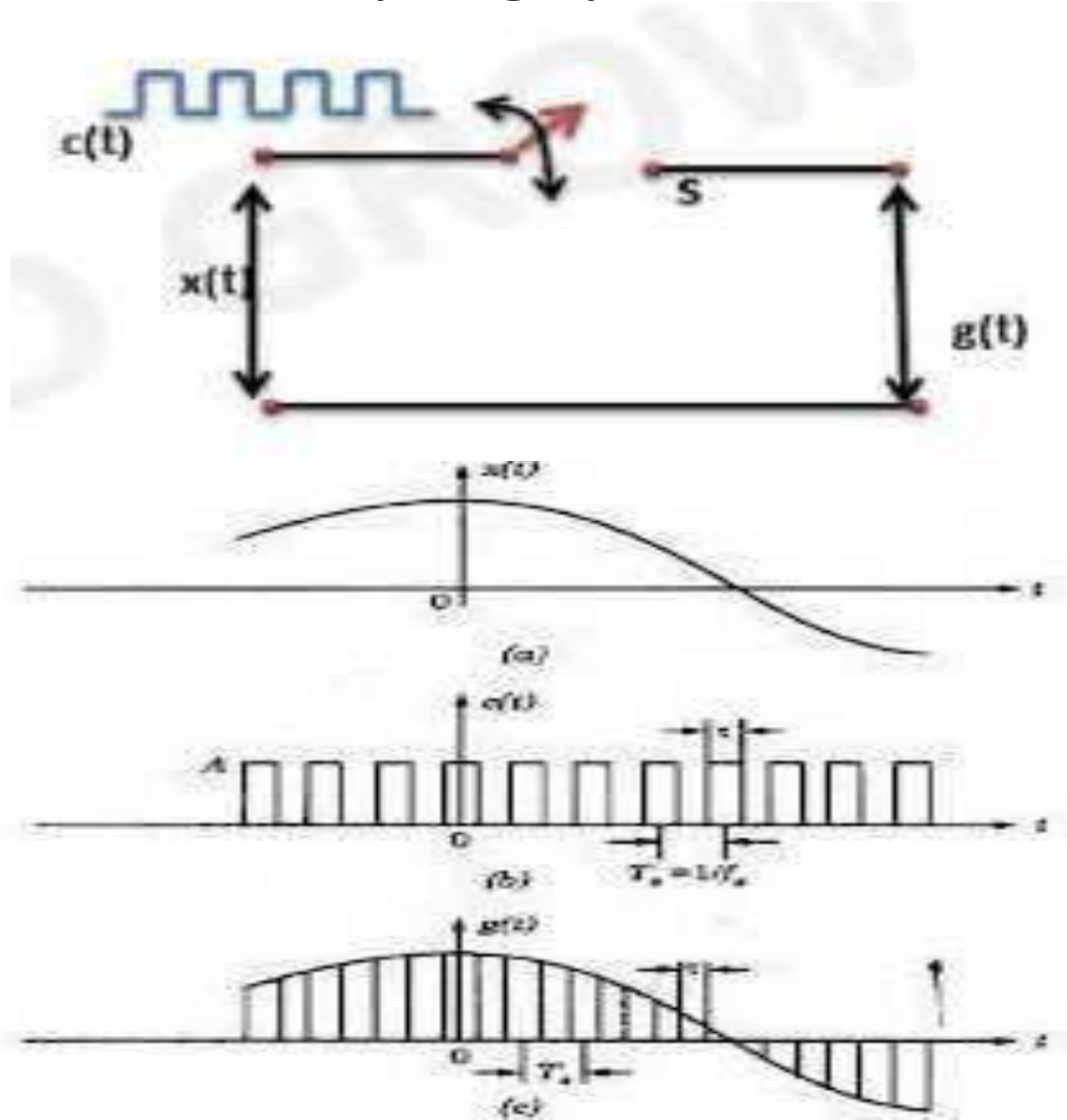

NATURAL SAMPLING

Let an analog continuous time signal $x(t)$ sampled at a rate f_s Hz and sampling function $c(t)$ which is a train of periodic pulse of width τ and frequency f_s Hz

Case i: When $c(t)$ is high

Switch S is closed and output $g(t)$ is exactly equal to input

$$g(t) = x(t)$$

NATURAL

SAMPLING

Case ii: When $c(t)$ is low

Switch s is open

$$g(t) = 0$$

The time domain representation of naturally sampled signal is given by,

$$g(t) = x(t) \sum_{n=-\alpha}^{\alpha} \frac{\tau A}{T_s} \text{Sinc}(fn \cdot \tau) e^{j2\pi fsnt}$$

The spectrum of naturally sampled signal is given by,

$$G(f) = \frac{\tau A}{T_s} \sum_{n=-\alpha}^{\alpha} \text{Sinc}(nfs\tau) X(f - nfs)$$

Pulse Width Modulation(PWM)

In PWM, the width of pulses of carrier pulse train is varied in proportion with amplitude of modulating signal.

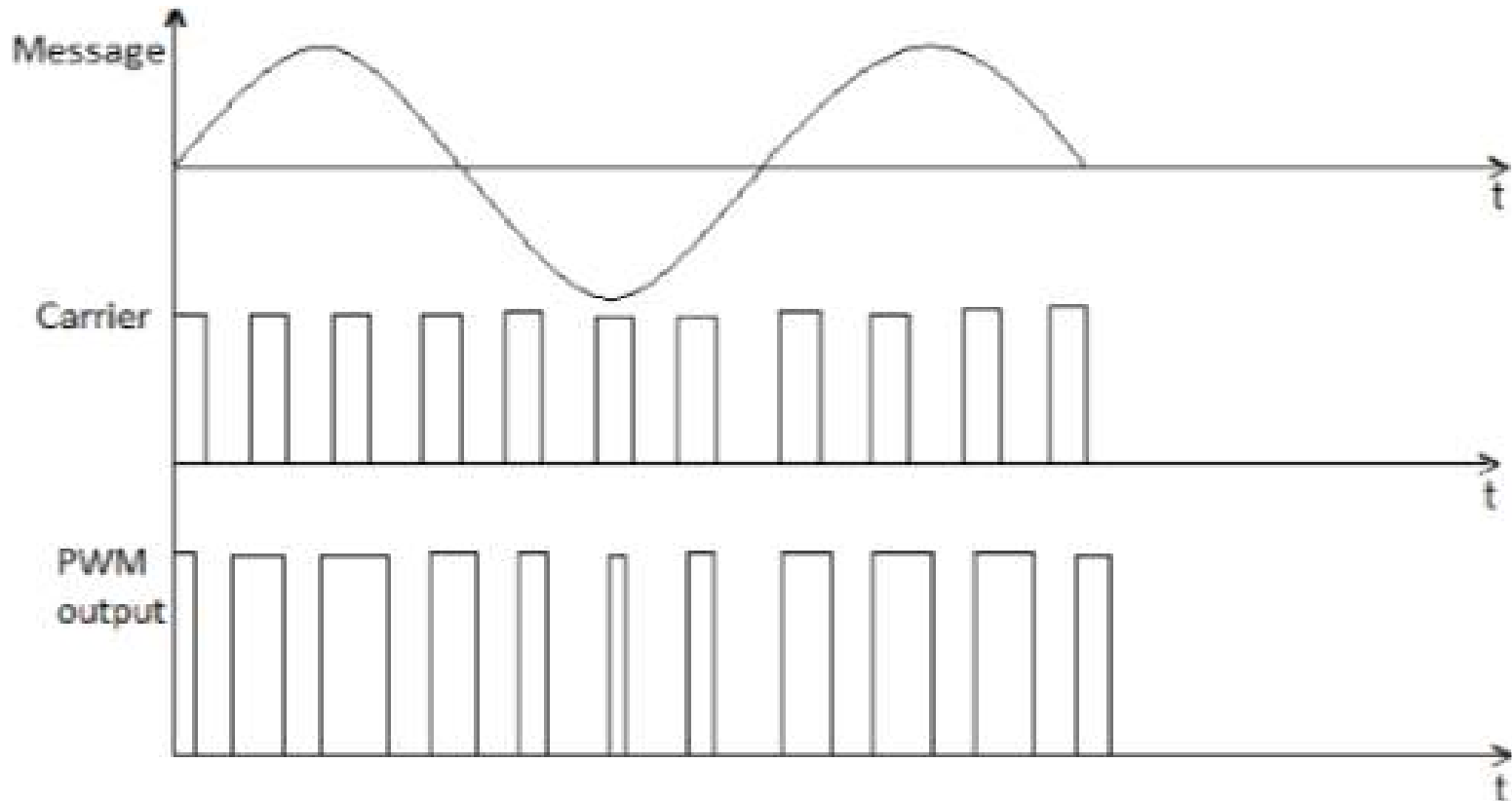

PWM GENERATION

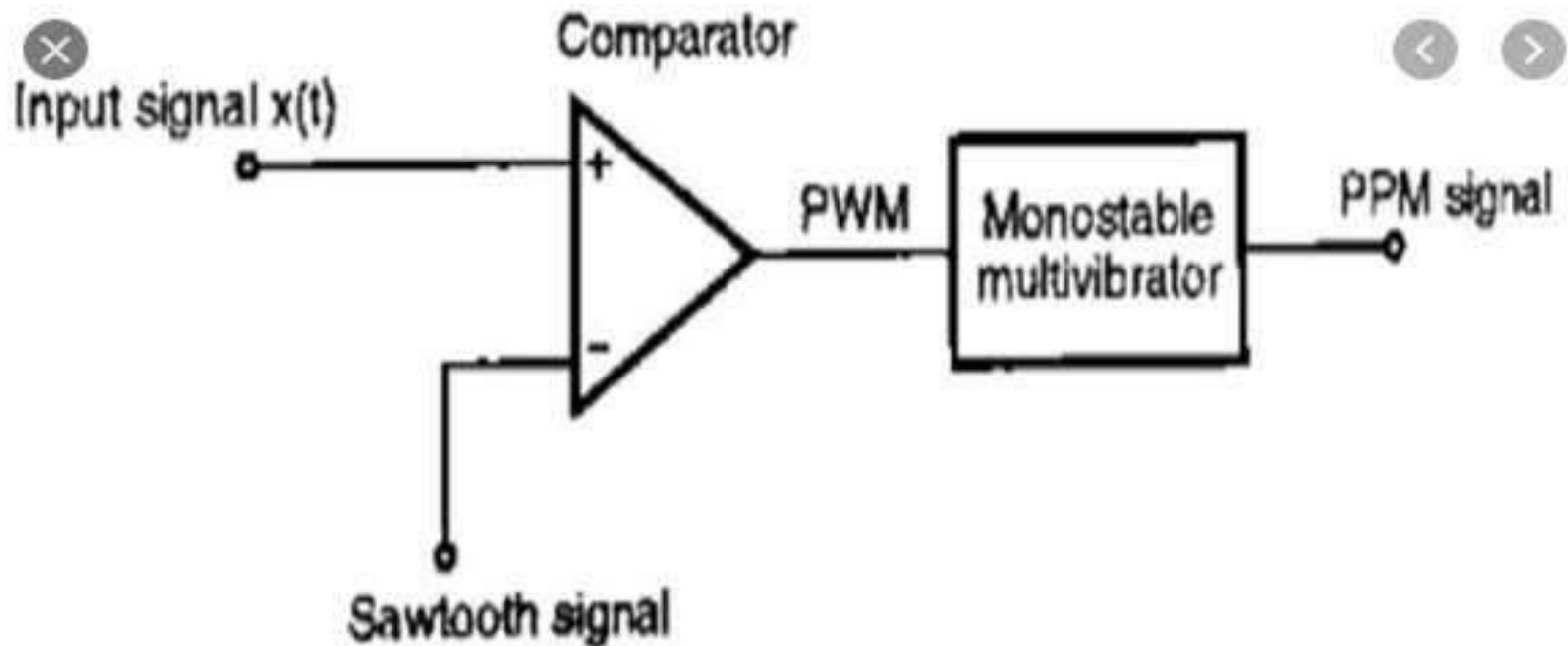

A sawtooth generator generates a sawtooth signal of frequency f_s .

This is applied to inverting terminal of comparator.

PWM

GENERATION

- Modulating signal $x(t)$ is applied to non-inverting terminal of comparator.
- Comparator output remains high as long as instantaneous amplitude of $x(t)$ is higher than sawtooth signal.
- This gives the PWM output at the output of comparator.
- The leading edges of PWM waveform coincide with falling edges of ramp signal
- Therefore, leading edges of PWM signal are always generated at fixed time intervals
- Occurrence of falling edge of PWM signal is dependent on instantaneous amplitude of $x(t)$

PWM GENERATION

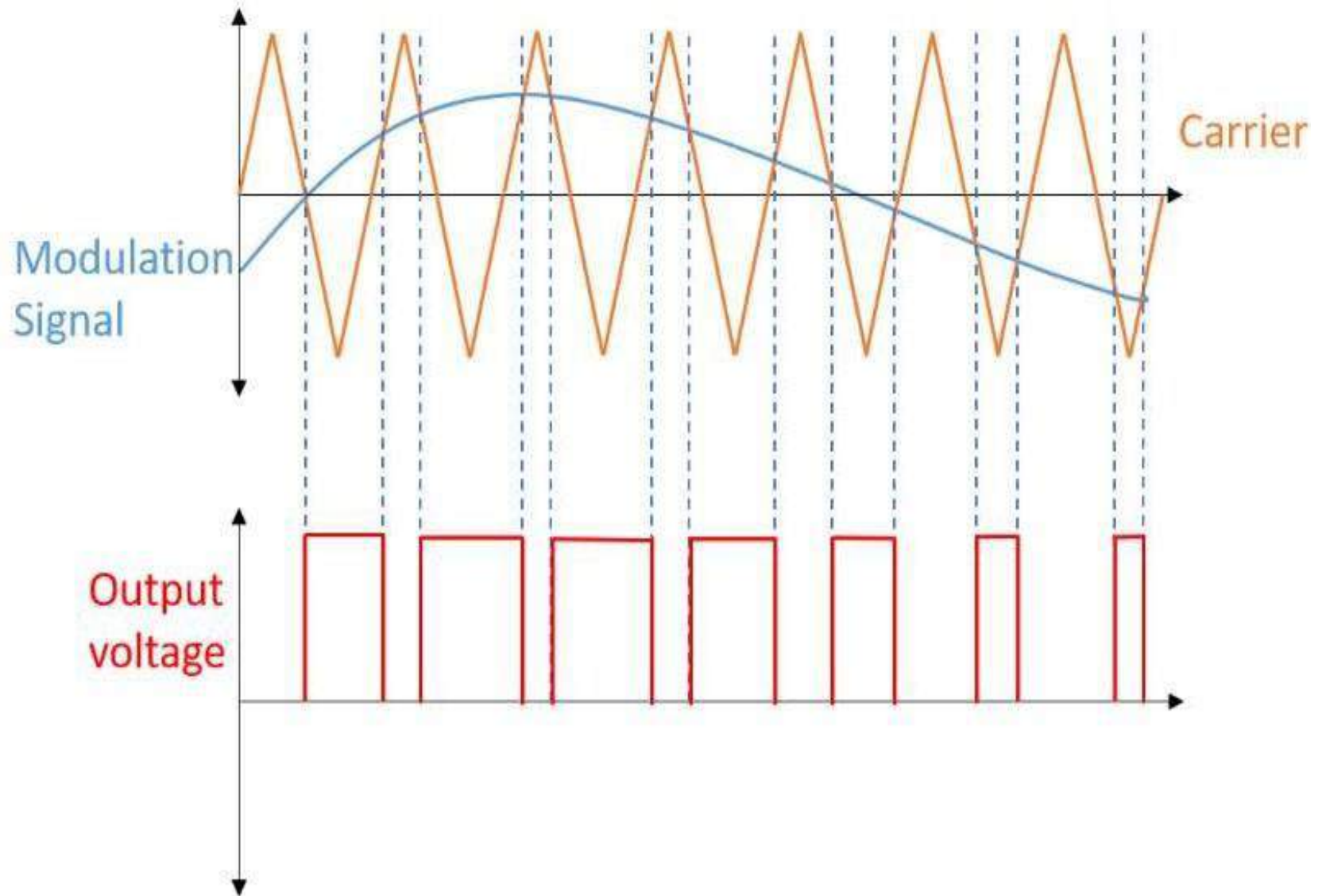

DETECTION OF PWM

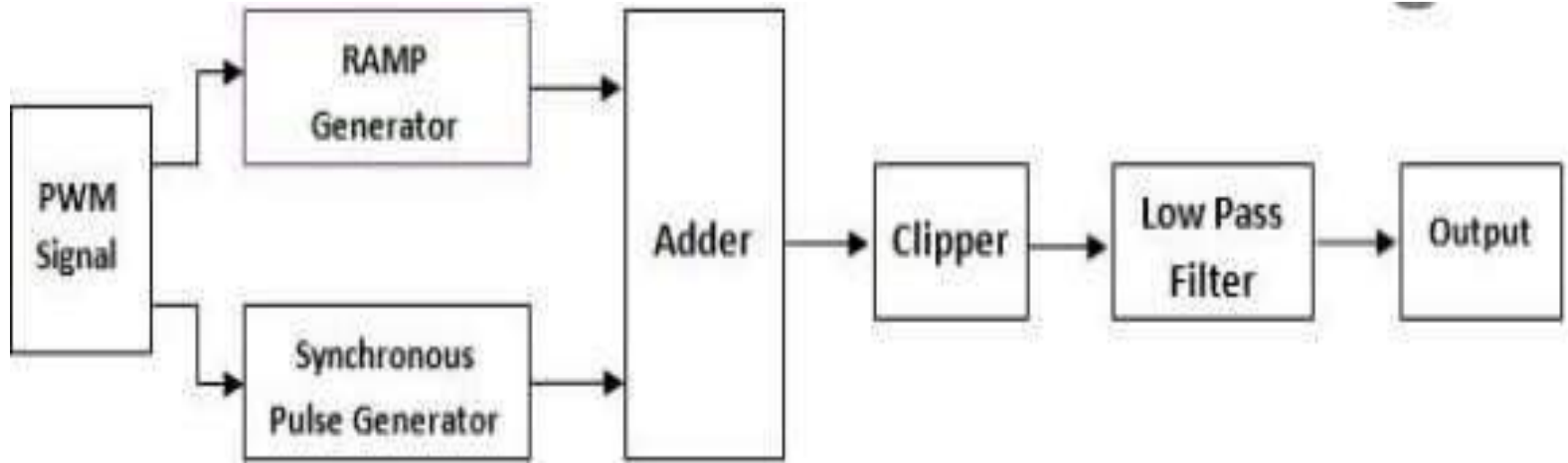

- The PWM signal received at the input of detector circuit will contain noise
- This signal is applied to a pulse generator which regenerates the PWM signal.
- Some of the noise is removed and the pulses are squared up.

DETECTION OF PWM

- The regenerated pulses are applied to a reference pulse generator.
- It produces a train of constant amplitude and constant width pulses.
- These pulses are synchronized to the leading edges of regenerated PWM pulses but delayed by fixed intervals.
- The regenerated PWM pulses are also applied to a ramp generator whose o/p is a constant slope ramp for the duration of the pulse.
- At the end of the pulse a sample and hold circuit retains the final ramp voltage until it is reset at the end of the pulse.
- The constant amplitude pulses at the o/p of the reference generator are then added to ramp signal.
- O/P of the adder is then clipped off at a threshold level to generate a PAM signal.
- A low pass filter is used to recover the original modulating signal back from PAM signal.

DETECTION OF

DM/M

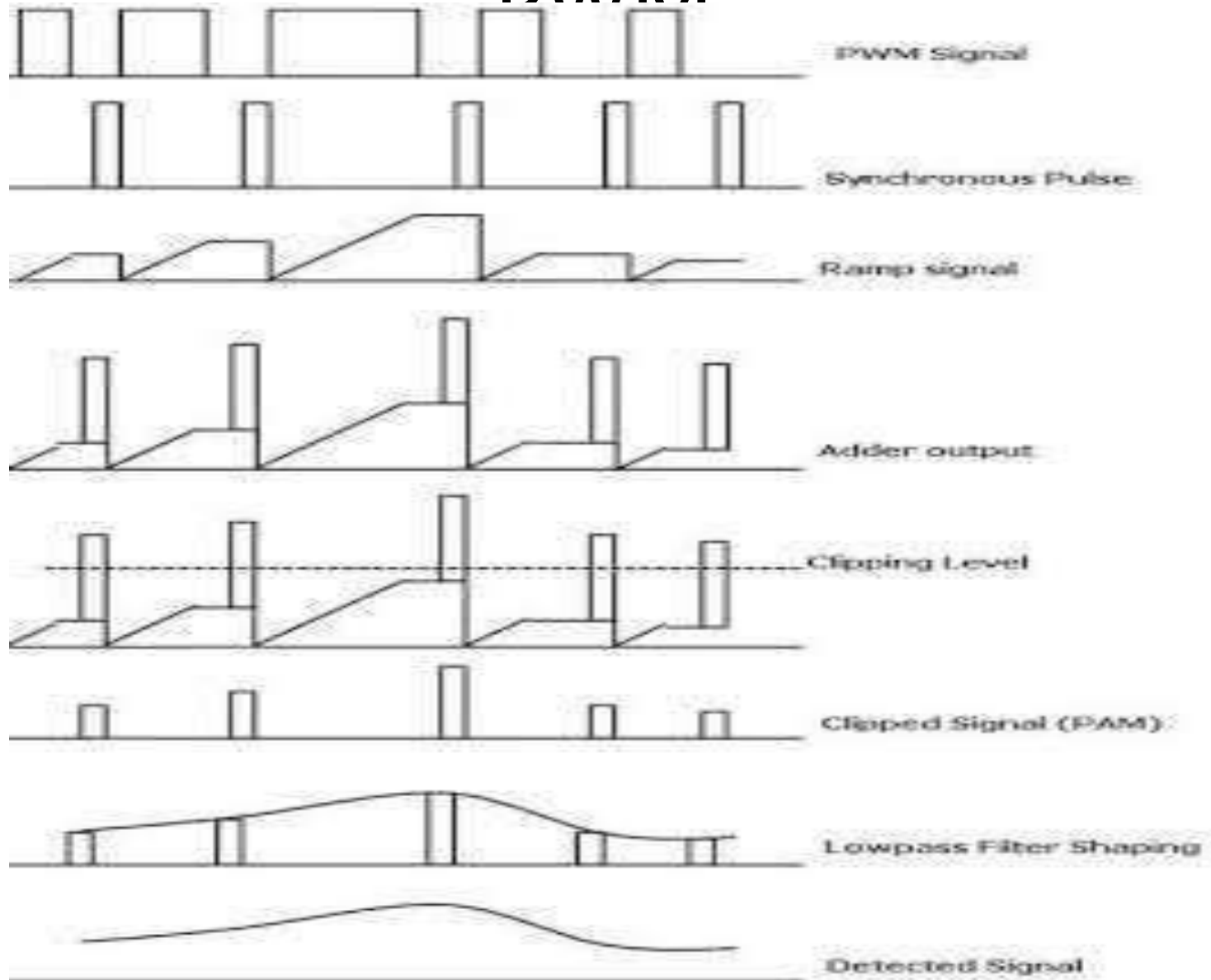

PULSE POSITION

MODULATION (PPM)

Modulation technique in which position of pulses of carrier pulse train is varied in accordance with amplitude of modulating signal.

Generation:

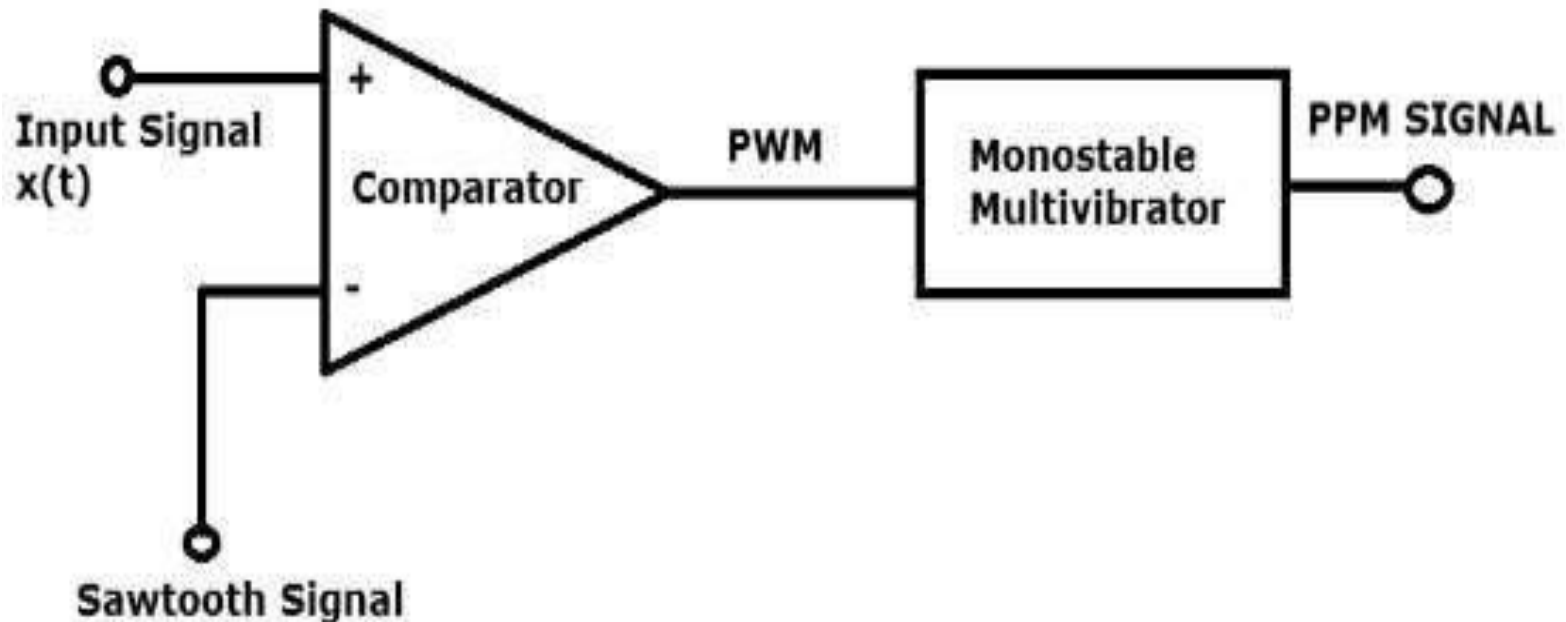

PPM

GENERATION

- The block diagram is similar to PWM except monostable multivibrator.
- PWM pulses obtained at the output of comparator are applied to a monostable multivibrator.
- monostable multivibrator is a negative edge triggered circuit. At each trailing edge of PWM signal the monostable output goes high.
- PPM output remains high for a fixed duration from trailing edge of PWM signal.

PPM GENERATION

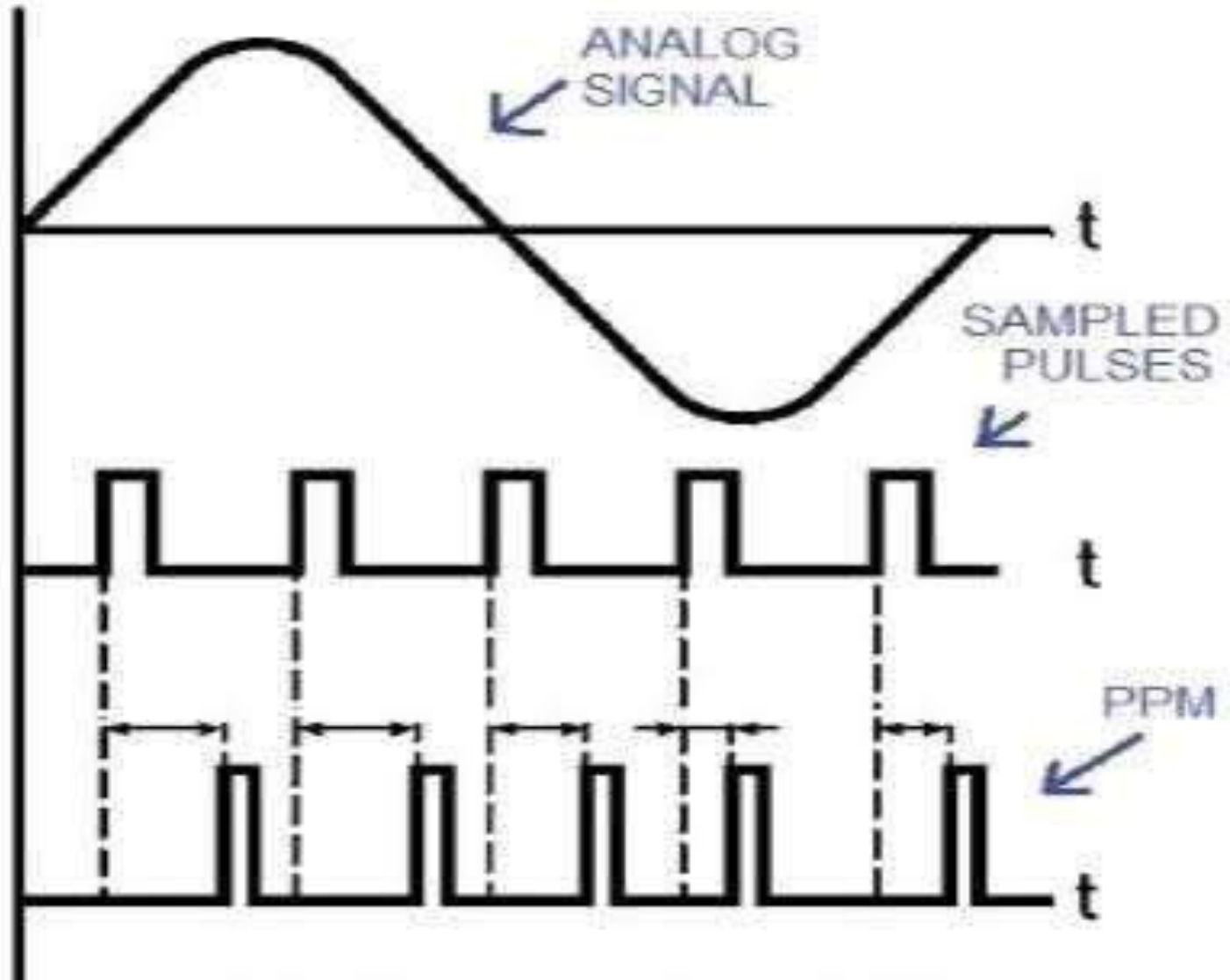

DETECTION OF PPM

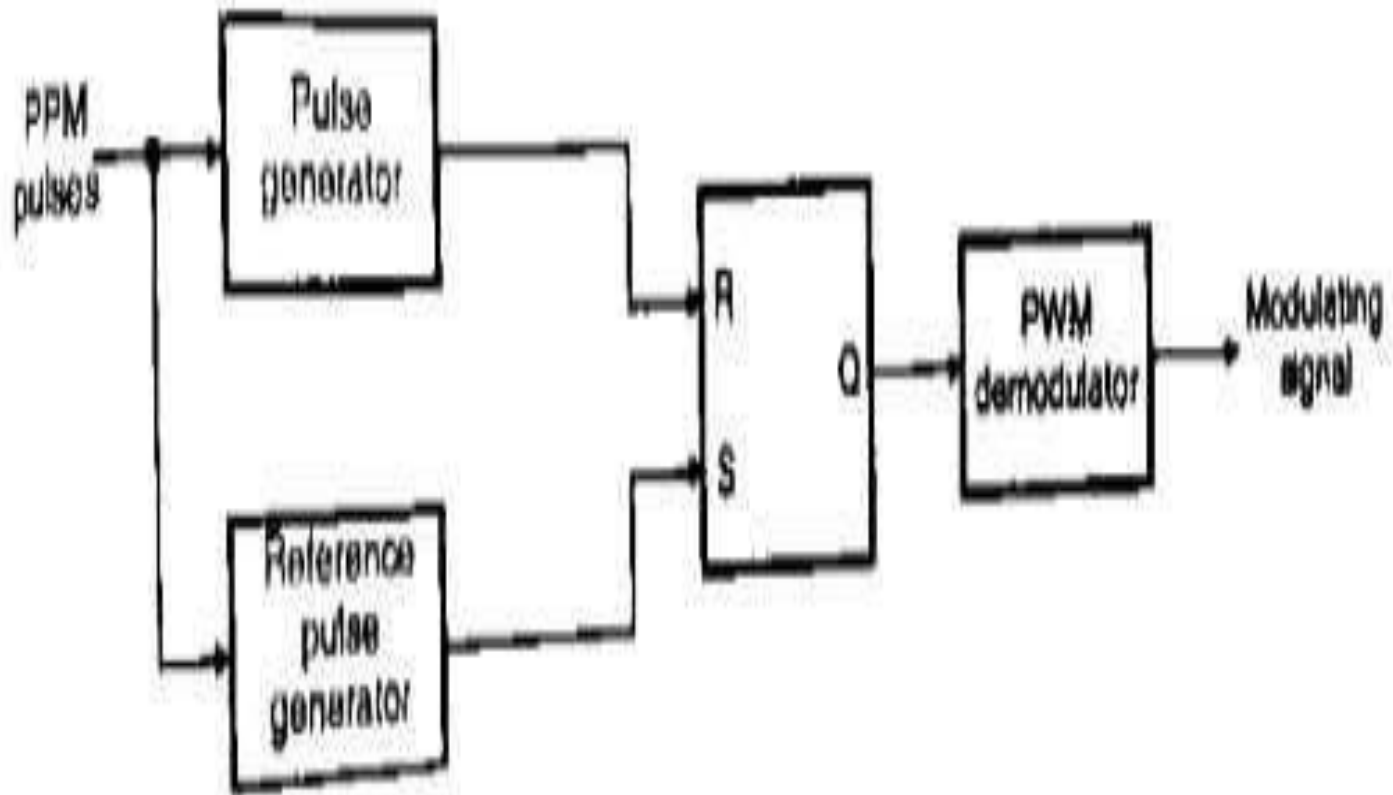

DETECTION OF PPM

- The circuit consists of S-R flipflop which is set or gives high output when reference pulses arrive.
- Reference pulses are generated by a reference pulse generator.
- Flip-flop circuit is reset and gives low output at the leading edge of PPM signal.
- The process repeats and we get PWM pulses at the output of flip-flop.
- PWM pulses are then demodulated in a PWM demodulator to get original modulating signal.

DETECTION OF

DDMA

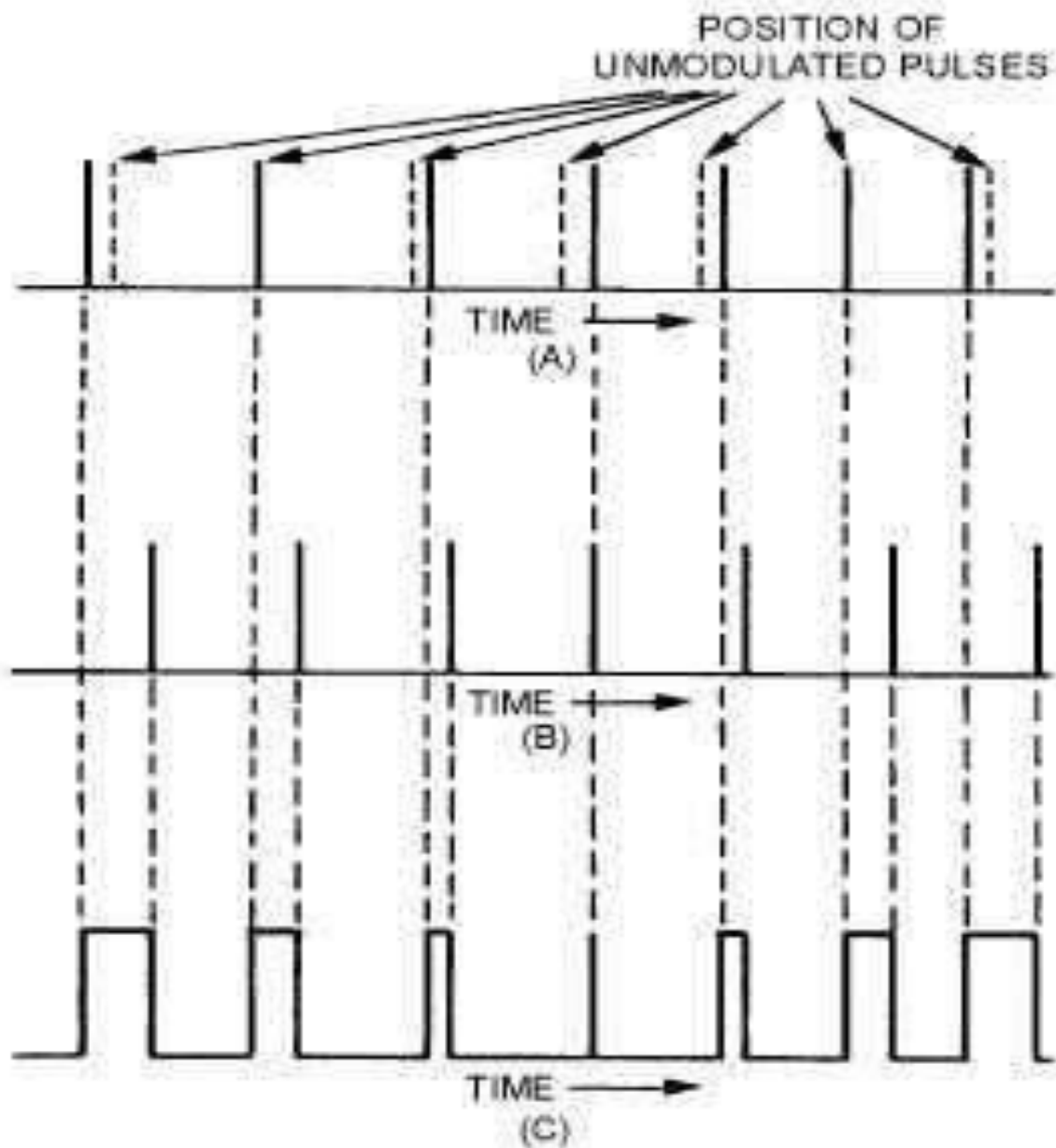

Radio receiver

measurements

The important characteristics of superheterodyne radio receiver are,

- Sensitivity
- Selectivity
- Fidelity

Sensitivity:

- It is defined as the ability of receiver to amplify weak signals
- It is defined in terms of voltage which must be applied at the receiver input terminals to provide a standard output power at the receiver output.

Radio receiver

measurements

- Sensitivity is expressed in millivolts
- For practical receivers sensitivity is expressed in terms of signal power required to produce minimum acceptable output with minimum acceptable noise.

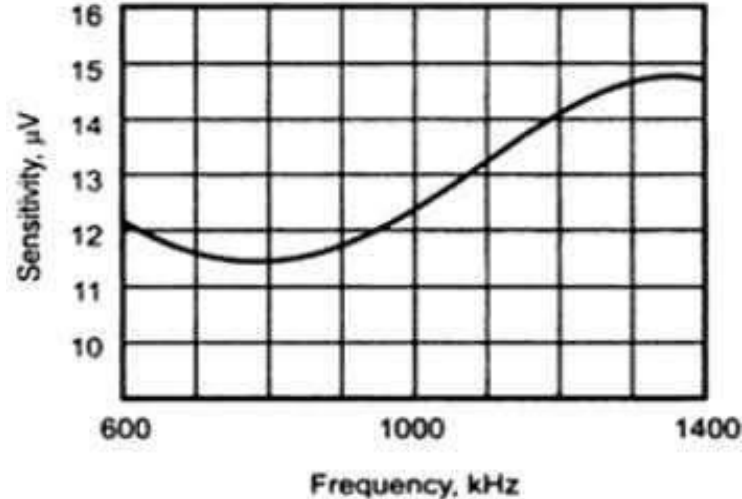

- Sensitivity of superheterodyne radio receiver depends on
- Gain of RF amplifier
- Gain of IF amplifier
- Noise figure of RX

Radio receiver measurements

Selectivity:

It is defined as the ability of receiver to reject unwanted signals.

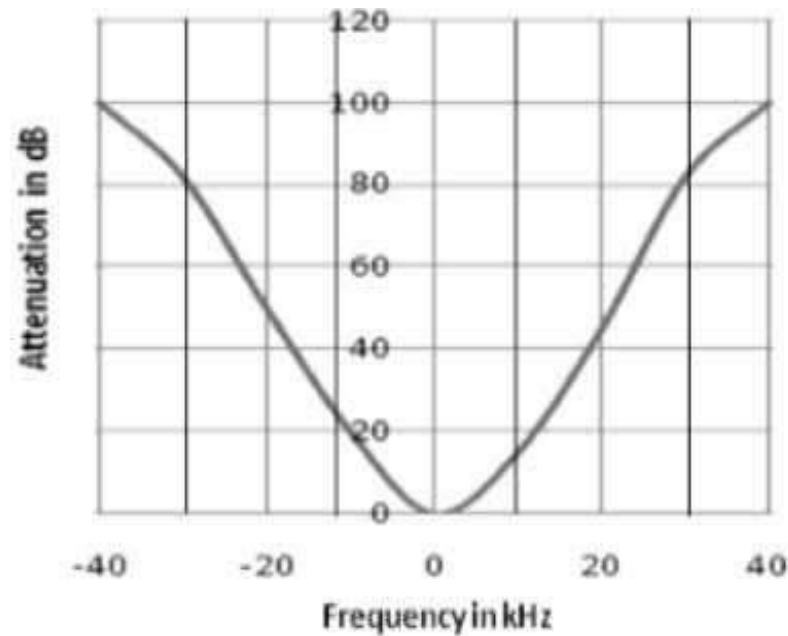

Selectivity depends on

- Receiving frequency
- Response of IF section

Radio receiver measurements

Fidelity:

It is the ability of a receiver to reproduce all the modulating frequencies equally.

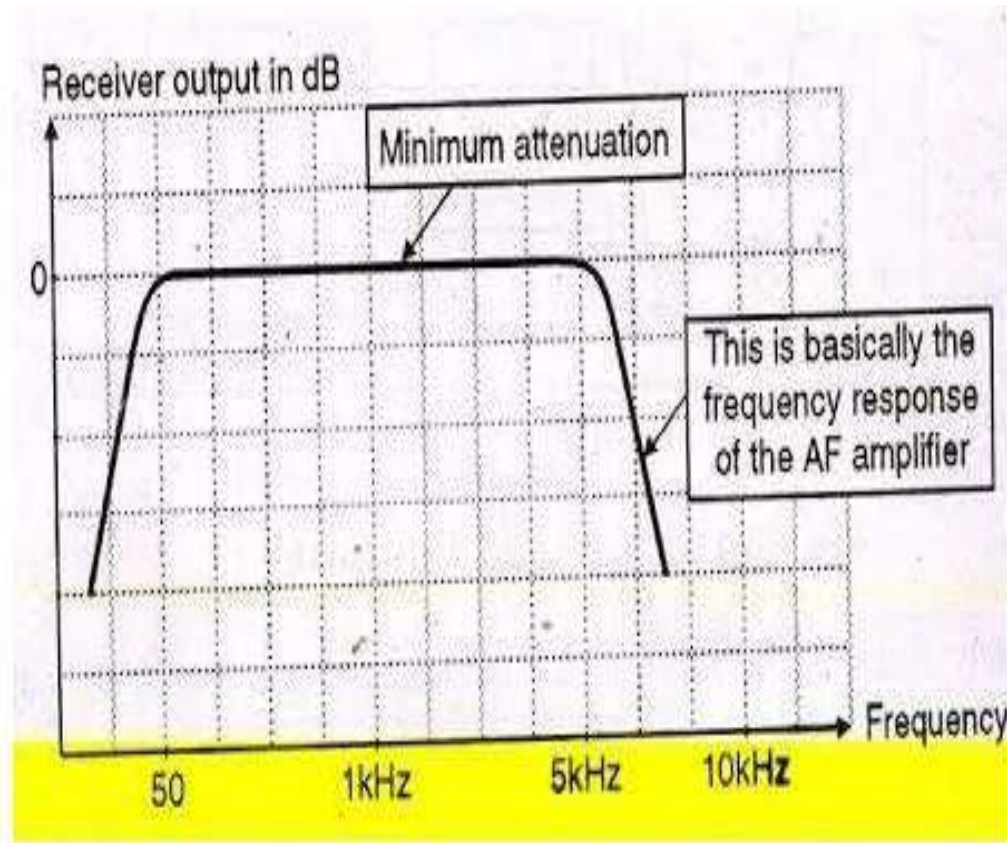

INFORMATION & CHANNEL CAPACITY

Information:

Information is defined as a sequence of letters, alphabets, symbols which carries a message with specific meaning.

Source of Information:

The sources of information can be divided into 2 types.

- Analog Information sources
- Digital information sources

Analog information sources produce continuous amplitude continuous time electrical waveforms.

Discrete information sources produces messages consisting of discrete letters or symbols.

Information content of a message

- The information content of a message is represented by the probability or uncertainty of the event associated with the message.
- The probability of occurrence of a message is inversely related to amount of information.
- Therefore, a message with least probability of occurrence will have maximum amount of information.
- The relation between information content of message and its probability of occurrence is given by,

$$I_k = \log (1/P_k)$$

- The unit of information is bit.
- $I_k = \log_2(1/P_k)$ bits, $I_k = \log_{10}(1/P_k)$ Decits, $I_k = \log_e(1/P_k)$ nats.

Entropy (Average information content)

Entropy is defined as the average amount of information conveyed by a message. It is denoted by H .

$$H(X) = \sum_{k=1}^M P_k \log \frac{1}{P_k}$$

Properties of Entropy:

1. Entropy is always non negative i.e $H(x) \geq 0$.
2. Entropy is zero when probability of all symbols is zero except probability one symbol is one.
3. Entropy is maximum when probability occurrence of all symbols is equal

i.e $H(x) = \log_2 M$

Entropy of symbols in long independent sequences

- In a statistically independent sequence the occurrence of a particular symbol during a time interval is independent of occurrence of symbols at other time interval.
- If $P_1, P_2, P_3, \dots, P_M$ are the probabilities of occurrences of M symbols, then the total information content of the message consisting N symbols is given by,

$$I_{total} = \sum_{k=1}^M N \cdot P_k \log\left(\frac{1}{P_k}\right) \text{ bits}$$

- To obtain entropy or average information per symbol, the total information content is divided by number of symbols in a message.

$$\text{Therefore, } H(X) = \frac{I_{total}}{N} = \sum_{k=1}^M P_k \log\frac{1}{P_k} \text{ bits/symbol}$$

Entropy of symbols in long dependent sequences

- In statistically dependent sequences, occurrence of one message alters the occurrence of other message.
- Due to this type of dependency, amount of information coming from a source is gradually decreased.
- To determine the entropy and information rate of symbols for long statistically dependent sequences a special model is developed which is **Markoff statistical model**.

Markoff statistical model for

information sources.
A random process in which probability of future values depends on probability of previous events is called Markoff process.

The sequence generated from such process is called Markoff sequence.

Entropy of Markoff sources:

Entropy of Markoff sources is defined as average entropy of each state.

$$H = \sum_{i=1}^n P_i H_i$$

$$H = \sum_{i=1}^n P_i \left[\sum_{j=1}^n P_{ij} \log \frac{1}{P_{ij}} \right]$$

Information rate of Markoff sources

The information rate of Markoff sources is given
by,

$$R = rH$$

Where, r = Rate at which symbols are generated

H = Entropy of Markoff sources

Information rate is measured in bits/sec

Different types of Entropies

Marginal Entropies:

$$H(X) = - \sum_{i=1}^M P(x_i) \log_2 P(x_i)$$

$$H(Y) = - \sum_{i=1}^M P(y_i) \log_2 P(y_i)$$

Joint entropy: $H(X,Y) = - \sum_{i=1}^M \sum_{j=1}^N P(x_i, y_j) \log_2 P(x_i, y_j)$

Conditional entropy: $H\left(\frac{Y}{X}\right) = - \sum_{i=1}^M \sum_{j=1}^N P(x_i, y_j) \log_2 \left(P\left(\frac{y_j}{x_i}\right) \right)$

Relation between Entropies: $H\left(\frac{X}{Y}\right) = - \sum_{i=1}^M \sum_{j=1}^N P(x_i, y_j) \log_2 \left(P\left(\frac{y_j}{x_i}\right) \right)$

$$H(X,Y) = H(X) + H(Y/X) = H(Y) + H(X/Y)$$

Mutual Information

$I(X; Y)$ of a channel is equal to difference between initial uncertainty and final uncertainty.

$I(X;Y) = \text{Initial uncertainty} - \text{final uncertainty.}$

$I(X;Y) = H(X) - H(X/Y)$ bits/symbol

Where, $H(X)$ - entropy of the source and $H(X/Y)$ - Conditional Entropy.

Properties of mutual information:

1. $I(X;Y) = I(Y;X)$

2. $I(X;Y) \geq 0$

3. $I(X;Y) = H(X) - H(X/Y)$

4. $I(X;Y) = H(X) + H(Y) - H(X,Y).$

Discrete communication channel

The communication channel in which both input and output is a sequence of symbols is called a discrete communication channel or coding channel.

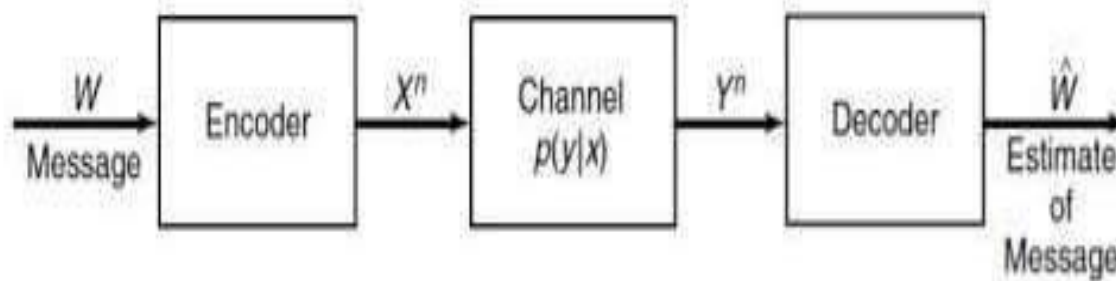

A discrete channel is characterized by a set of transition probability P_{ij} which depends on the parameters of modulator, transmission medium or channel, noise and demodulator.

Discrete communication channel

The input to the discrete channel is any of the M symbols of an alphabet provided and output is the symbol belonging to same alphabet.

Model of discrete channel is shown below:

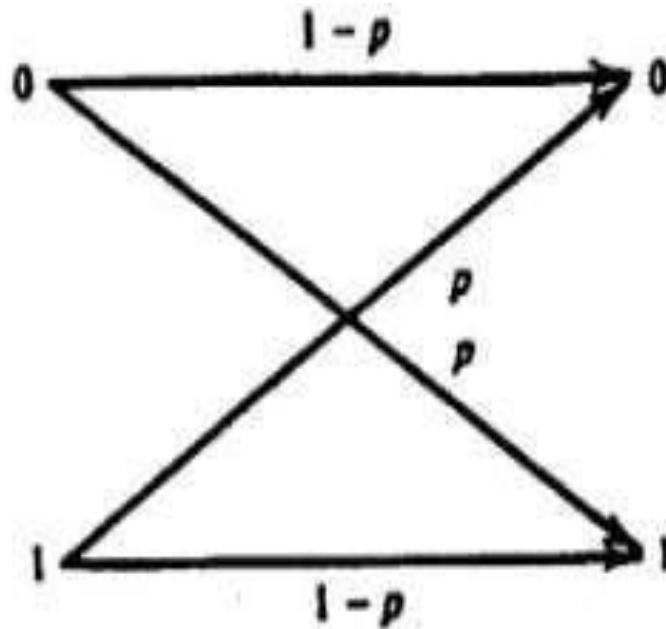

Rate of information over a discrete channel

- In discrete channels, the average rate of information transmission is assumed to be the difference between input data rate and error rate.
- The average rate of information transmission of a discrete channel is defined as the amount of information transmitted over the channel minus information lost.
- It is denoted by D_t and is given by,

$$D_t \cong \left[H(X) - H\left(\frac{X}{Y}\right) \right] r_s$$

Capacity of discrete memoryless channel

The maximum allowable rate of information that can be transmitted over a discrete channel is called capacity of memoryless channel.

When channel matches with the source, maximum rate of transmission takes place.

Therefore, channel capacity,

$$C = \max [I(X,Y)] = \text{Max} [H(X) - H(X/Y)]$$

M-Ary discrete memoryless channel

The channel which transmit and receive one of the 'm' possible symbols depending on the present input and independent of previous input is called M-Ary discrete memoryless channel.

The relation between conditional entropy and joint entropy can be written as,

$$H(X,Y) = H(X/Y) + H(Y) = H(Y/X) + H(X)$$

Capacity of Gaussian channel- Shannon Hartley Theorem

Shannon- Hartley theorem states that the capacity of Gaussian channel having bandwidth 'W' is given as,

$$C = W \log_2 \left[1 + \frac{S}{N} \right] \text{ bits/sec}$$

Where, W = Channel bandwidth

S= Average signal power

N= Average noise power

Shannon- Fano algorithm

Shannon Fano coding is source encoding technique which is used to remove the redundancy (repeated information). The following steps are involved

1. For a given list of symbols, develop a corresponding list of probabilities or frequency counts so that each symbol's relative frequency of occurrence is known.
2. Sort the lists of symbols according to frequency, with the most frequently occurring symbols at the left and the least common at the right.

Shannon- Fano

algorithm

3. Divide the list into two parts, with the total frequency counts of the left part being as close to the total of the right as possible.
4. The left part of the list is assigned the binary digit 0, and the right part is assigned the digit 1. This means that the codes for the symbols in the first part will all start with 0, and the codes in the second part will all start with 1.
5. Recursively apply the steps 3 and 4 to each of the two halves, subdividing groups and adding bits to the codes until each symbol has become a corresponding code leaf on the tree.